

Installation and Operating Manual

TESVOLT FORTON

with KACO blueplanet gridsave 92.0
FORTON/12-30



TESVOLT
Free to go green.

TESVOLT AG
Am Heideberg 31
06886 Lutherstadt Wittenberg
Germany
Telephone: +49 (0) 3491 87 97 - 200
Email: service@tesvolt.com
Internet: www.tesvolt.com

RD.TI.143.en-UK

© TESVOLT AG 2026

Table of contents

1	Important information about this document.	7
1.1	Scope.	7
1.2	Target group.	7
1.3	Other applicable documents.	7
1.4	Disclaimer.	7
1.5	Figures.	8
1.6	Guarantee.	8
1.7	TESVOLT Service.	8
2	Explanation of symbols and safety instructions.	9
2.1	Explanation of symbols.	9
2.2	General safety instructions.	9
2.3	Symbols on the unit.	20
2.4	Appropriate use	23
3	Product information.	24
3.1	Scope of delivery.	24
3.2	Product overview.	25
3.3	Battery module connections.	26
3.4	Connections and layout of the high-voltage unit (HV unit).	27
3.5	External connecting terminals.	29
3.6	Aerosol fire extinguishing system.	30
3.6.1	Overview.	30
3.6.2	Functional principle.	30
3.7	Environmental control system.	31
3.8	Dimensions.	33
3.9	Technical Data.	33
3.9.1	Technical data for the energy storage system.	33
3.9.2	Technical data for the battery.	34
3.9.3	Technical data for the KACO battery inverter.	35
3.10	Type plate.	36
4	Transport.	37
4.1	Transport to the end customer.	37
4.2	Transport at end-customer site.	38
4.3	Removing packaging.	39
4.4	Storage.	39

5	Installation.	40
5.1	Required Tools.	40
5.2	Installation site.	41
5.2.1	Installation conditions.	41
5.2.2	Installation plan.	42
5.2.3	Recommended minimum foundation areas.	48
5.2.4	Connection anchor requirements.	50
5.2.5	Setting up the energy storage system.	51
5.3	Installing the battery inverter (wall mounting).	51
5.3.1	Removing the battery inverter.	52
5.3.2	Installing the battery inverter.	53
6	Electrical connection.	54
6.1	System examples.	57
6.2	Overview of cable entries.	59
6.3	Installing the grounding.	60
6.4	Installing the weather canopy.	61
6.5	Installing the side base cover.	61
6.6	Connecting the module connectors.	62
6.7	Connecting the HV unit.	62
6.8	Removing the cable cover.	63
6.9	Installing cables.	64
6.9.1	Installing the communication cables.	64
6.9.2	Connecting two energy storage systems.	65
6.9.3	Installing the DC connecting cables.	65
6.10	Connecting the external fire alarm system.	66
6.11	Installing the aerosol fire extinguishing system.	67
6.12	AC connection of the KACO blueplanet 92kW TL3.	67
6.12.1	Connecting the battery inverter to the utility grid.	69
6.13	Installing the AC auxiliary power cable.	71
6.14	Installing the cable cover.	73
6.15	Janitza UMG 604-Pro power analyser.	73
6.16	Installing the base cover.	73
7	Commissioning.	74
7.1	Testing the system.	74
7.2	Configuring the Janitza power analyser.	75
7.2.1	Adding the power analyser in GridVis.	76
7.2.2	Checking the configuration.	79
7.3	Switching on the KACO battery inverter.	80
7.4	Commissioning the energy storage system.	80

7.5	Commissioning the KACO battery inverter.	80
7.6	Commissioning the TESVOLT IoT gateway.	83
7.6.1	Logging into the TESVOLT IoT gateway.	84
7.6.2	Registering in the TESVOLT Cloud.	84
7.6.3	Installation.	85
7.7	Commissioning the TESVOLT Energy Manager.	86
7.8	Setting up and configuring the system in the TESVOLT portal.	89
8	Operation.	91
8.1	Signal elements on the energy storage system.	92
8.2	Signal elements on the battery inverter.	93
9	Decommissioning.	96
9.1	Shutting down the energy storage system.	96
9.2	Activating emergency shutdown.	96
10	Inspection and maintenance.	97
10.1	Switching the system on and off for maintenance.	98
10.1.1	Switching on the system.	98
10.1.2	Switching off the system.	98
10.2	Annual maintenance.	98
10.3	Other maintenance tasks.	99
10.4	Maintenance during normal operation.	100
10.5	Maintenance in case of prolonged downtime.	100
10.6	Replacing the battery module.	100
10.7	Replacing the high-voltage unit.	100
10.8	Maintaining the heat exchanger.	101
10.9	Replacing the smoke detector.	102
10.9.1	Preparatory work.	102
10.9.2	Removing the smoke detector.	102
10.9.3	Installing the smoke detector.	103
10.10	Replacing the temperature sensor.	103
10.10.1	Preparatory work.	103
10.10.2	Removing the temperature sensor.	103
10.10.3	Installing the temperature sensor.	103
10.11	Replacing the CO detector.	104
10.11.1	Preparatory work.	104
10.11.2	Removing the CO detector.	104
10.11.3	Installing the CO detector.	104

10.12	Replacing the lead-acid batteries in the UPS.	105
10.12.1	Preparatory work.	105
10.12.2	Replacing the lead-acid batteries.	106
10.12.3	Final work.	106
10.13	Repairing the paintwork.	107
10.13.1	Requirements.	107
10.13.2	Carrying out paintwork repairs.	108
11	Disposal.	109

1 Important information about this document

1.1 Scope

This Installation and Operating Manual applies to the TESVOLT FORTON energy storage system.

This Installation and Operating Manual applies to the Federal Republic of Germany only, without restriction. Please ensure that you adhere to the applicable local legal regulations and standards. The standards and legal regulations in other countries may contradict the specifications in this manual. In this case, please contact *TESVOLT Service*. → *Chapter 1.7 'TESVOLT Service' on page 8*

1.2 Target group

This Installation and Operating Manual is intended exclusively for qualified electricians. This document must be read carefully beforehand to ensure error-free installation and commissioning. The Installation and Operating Manual should be kept in the vicinity of the energy storage system and must be accessible at all times to all individuals involved in installation or maintenance.

Requirements for installers

The installation of the energy storage system may be carried out only by qualified electricians who have the following qualifications:

- Training in dealing with hazards and risks associated with installing and operating electrical equipment, systems and batteries
- Training in installing and commissioning electrical equipment
- Knowledge of and compliance with the technical connection conditions, standards, guidelines, regulations and laws applicable to the location
- Knowledge of how to handle lithium-ion batteries (transport, storage, disposal, sources of danger)
- Knowledge of and compliance with this Installation and Operating Manual and other applicable documents



You can find information about the training courses at www.tesvolt.com. For further information, please send an email to academy@tesvolt.com.

1.3 Other applicable documents

- **Manual** for the KACO blueplanet gridsave 92.0 TL3-S battery inverter from KACO new energy GmbH
- Installation plan
- Foundation recommendation

1.4 Disclaimer

TESVOLT AG assumes no liability for personal injury, damage to property, damage to the product or subsequent damage that is attributable to the following causes:

- Non-compliance with this manual
 - Improper use of the product
 - Use of non-approved spare parts and accessories
- Unauthorised modifications or technical changes to the product are prohibited.

1.5 Figures

All figures in this Installation and Operating Manual are provided for illustrative purposes only and may differ from the actual design of the product when it comes to features, labelling or appearance. This is particularly relevant to product variations and technical changes.

1.6 Guarantee

The current guarantee conditions can be downloaded from the internet by visiting ↪ www.tesvolt.com.

1.7 TESVOLT Service

TESVOLT Service can be contacted by phone or email:

German: Phone **+49 (0) 3491 87 97 - 200** or email ↪ service@tesvolt.com.

English: Phone **+49 (0) 3491 87 97 - 240** or email
↪ service.international@tesvolt.com.

2 Explanation of symbols and safety instructions

2.1 Explanation of symbols

Warnings

Warnings contain safety-related information and must therefore always be observed. They use signal words to warn of possible hazards and indicate specific measures for avoiding these hazards.

The following signal words are defined and used in this document:

DANGER

Danger refers to an imminent risk. Death or serious injuries will result if not avoided.

WARNING

Warning refers to a potentially impending risk. Death or serious injuries may result if not avoided.

CAUTION

Caution refers to a potentially impending risk. Slight or minor injuries may result if not avoided.

NOTICE

A **notice** refers to a potentially harmful situation. If not avoided, a device or something in its vicinity may be damaged.

Important information



Important information that does not pose a risk to people or property is marked with this information symbol.

2.2 General safety instructions

This manual cannot describe every conceivable situation. For this reason, the applicable standards and corresponding occupational health and safety regulations always take priority.

The energy storage system has been developed in accordance with the battery safety standards IEC 62619, IEC 62477, ISO 13849 (all parts) and UN38.3, with a special emphasis on functional safety. The energy storage system meets the requirements for performance level C.

WARNING

Danger of death due to electric shock!

There is a risk of electric shocks when working on the energy storage system.

- Follow the safety and warning instructions issued by the manufacturer of the energy storage system and battery inverter.

 **WARNING****Danger of death due to fire!**

Overvoltage, short circuits, cell defects or incorrect handling pose a risk of fire.

- The energy storage system is equipped with a fire extinguishing system.

 **CAUTION****Risk of chemical burns from hydrofluoric acid!**

There is a risk of hydrofluoric acid forming if the battery modules are extinguished directly with water. This substance is highly corrosive and can be absorbed through the skin, eyes and mucous membranes.

- Fires on the energy storage system may only be extinguished by specialist personnel.
- Wear protective clothing when extinguishing fires on the energy storage system.

 **CAUTION****Risk of injury due to sharp edges, corners and protruding parts!**

As a result of the production process, the energy storage system may have sharp corners and edges, both internally and externally. In addition, it is designed to have protruding parts and there is a risk of colliding with these.

- Follow workplace safety regulations issued by professional associations and the government.

 **CAUTION****Risk of injury due to cutting!**

Cutting injuries can occur when cutting and stripping cables/wires.

- Use suitable safety tools.
- Wear personal protective equipment (e.g. work safety gloves).

 **CAUTION****General safety requirements**

- Do not dismantle or modify the system.
- Read the entire Installation and Operating Manual before use and comply with all the safety regulations and instructions.
- All installations must comply with local laws, regulations and standards.

 **CAUTION****Electrical safety**

- Work on the energy storage system may only be carried out by qualified electricians.
- Before starting work, apply the 5 safety rules and verify the absence of voltage on all poles. Allow sufficient time for the internal capacitors to discharge.
- Install the protective grounding first and remove it last.
- Always use insulated tools and wear appropriate personal protective equipment.
- Check that the insulation of all components and cables is undamaged.
- The battery terminals remain permanently energised; in the event of a short circuit, the resulting high currents can cause severe electric arcs and burns.
- Never disconnect or connect the DC connectors under load.

 **CAUTION****Personal safety**

- Wear insulated gloves, safety goggles, a hard hat, safety boots and a reflective vest.
- Do not wear or carry any metallic objects. Watches, rings, bracelets or chains can cause electrical discharges.
- After switching off the system, wait five minutes before touching any parts.
- If you suffer an electric shock, seek medical attention immediately.

 **CAUTION****Battery safety**

- Do not expose the battery modules to mechanical loads or impacts.
- Do not open or pierce the battery modules – the electrolyte is toxic.
- Avoid contact with battery fluid – take protective measures immediately in case of leaks.
- Do not throw the battery modules into a fire or expose them to high temperatures.
- To prevent short circuits, do not connect any metallic objects to the battery modules.
- To avoid damage caused by deep discharge, recharge the batteries immediately after use.

 **CAUTION****Environmental safety**

- Do not install or operate the system in potentially explosive environments.
- Install the energy storage system on a stable, fire-proof surface.
- Do not install the system in salty environments.
- Do not block the ventilation slots or cooling systems.

 CAUTION**Mechanical safety**

- Wear a safety harness when working at height.
- Only move heavy parts with suitable lifting equipment or the assistance of other people.
- Do not place any additional devices or equipment on the energy storage system.
- Always use suitable auxiliary equipment (e.g. forklifts with sufficient load capacity) to transport the system.

Personal protection** DANGER****Danger of death due to electric shock!**

Touching live parts can cause electric shock, arcing, sparking, fire or explosion.

- Before working on the energy storage system, isolate it and secure it against re-energisation.
- Ensure that the dielectric strength complies with applicable local laws, regulations, standards and specifications.
- Do not perform any work unless the unit has been isolated, secured against re-energisation and the absence of voltage has been verified (5 safety rules).
- Wear suitable personal protective equipment (PPE), e.g. insulating gloves, safety goggles and flame-retardant clothing.
- Only use insulated tools.

 DANGER**Danger of death due to electric shock!**

Metallic jewellery and other conductive objects can cause an electric shock in the event of accidental contact with live parts.

- Remove all jewellery and other conductive objects before entering the work area.
- Wear suitable personal protective equipment (PPE), e.g. insulating gloves, safety goggles and flame-retardant clothing.
- Only use insulated tools.
- Do not perform any work unless the unit has been isolated, secured against re-energisation and the absence of voltage has been verified (5 safety rules).
- Maintain the minimum distances from live parts.

 WARNING**Danger of death due to residual voltage!**

Live parts may remain energised for some time, including after a power failure.

- Do not touch live parts for 15 minutes after they have been switched off or after a power failure.

 **WARNING****Electric shock, arcing and mechanical hazards!**

Failure to wear suitable personal protective equipment (PPE) during work increases the risk of electric shocks, arcing injuries and mechanical damage. This can lead to serious injuries, burns or even death.

- Wear suitable personal protective equipment (PPE), e.g. insulating gloves, safety goggles and flame-retardant clothing.
- Check the PPE for integrity and compliance with standards before starting work.
- Follow internal safety procedures and applicable standards (e.g. EN 50110, IEC 60903).

 **CAUTION****Risk of injury due to burns!**

Contact with the copper rail, contacts or live connections can lead to burns.

- Before working on the energy storage system, isolate it and secure it against re-energisation.
- Avoid contact with live parts.
- Do not perform any work unless the unit has been isolated, secured against re-energisation and the absence of voltage has been verified (5 safety rules).
- Wear suitable personal protective equipment (PPE), e.g. insulating gloves, safety goggles and flame-retardant clothing.
- Only use insulated tools.

Electrical safety **DANGER****Danger due to damaged unit!**

Connecting cables to a damaged unit can lead to electric shocks, short circuits, fires or serious injuries.

- Before connecting cables, check the unit carefully for integrity and damage.
- Do not establish a connection if there are visible signs of damage (e.g. cracks, loose parts, burnt components).
- Do not put the unit into operation if it is damaged; report the issue and have repairs carried out in accordance with internal processes.
- Observe applicable standards and safety procedures for electrical systems.

 **DANGER****Danger from foreign objects entering the unit!**

Foreign objects entering the unit during operation can cause damage to equipment, reduced power output, power failures or personal injury.

- Keep the work area clean and free of loose objects.
- Prevent dust, liquids, tools or other foreign objects from entering the device.
- If necessary, use covers or protective devices to protect the unit during operation.
- Observe the manufacturer's instructions and all internal safety procedures.

 **DANGER****Danger due to missing or defective grounding!**

Missing or defective grounding can lead to a hazardous touch current. This can cause electric shocks, personal injuries, damage to equipment or fire.

- Before connecting the input voltage, make sure that the grounding is reliable and complies with standards.
- Ground the energy storage system in accordance with applicable local laws, regulations, standards and specifications (e.g. VDE, IEC).
- Check grounding connections regularly to ensure they are secure and free of corrosion.
- Only perform work on live parts after verifying the absence of voltage and conducting a grounding check.

 **WARNING****Danger if the protective grounding cable is connected or disconnected in the wrong order!**

Connecting or disconnecting the protective grounding cable in the wrong order can lead to electric shock, personal injury or damage to equipment.

- When connecting, connect the protective grounding cable first, before any other cables or parts.
- When disconnecting, disconnect the protective grounding cable last, after all other cables and parts.
- Ensure that the grounding connection is secure and conforms to standards.
- Observe applicable standards and regulations (e.g. VDE, IEC).

 **NOTICE****Impaired air circulation!**

Placing cables close to air inlets or outlets can impede the circulation of air.

- Do not lay cables close to the unit's air inlets or outlets.

Environmental requirements **DANGER****Explosion and fire due to flammable or explosive environment!**

Operation or use of the unit in environments containing flammable or explosive gases, vapours or smoke can result in explosion, fire, serious injury or death.

- Do not install or operate the unit in areas containing flammable or explosive gases, vapours or smoke.
- Before starting work, ensure that the environment is free of hazardous gases and smoke.
- When working in potentially hazardous areas, use suitable gas detectors and ensure adequate ventilation.
- Observe applicable safety procedures and standards (e.g. ATEX, IECEx).

 **DANGER****Risk of fire and overheating due to heat sources or open flames!**

Positioning the unit near sources of heat or open flames can lead to overheating, damage to equipment, fire or personal injury.

- Do not position the unit near heaters, candles, sources of smoke or other heat sources.
- Maintain the minimum distances from heat sources in accordance with the manufacturer's specifications.
- Monitor the ambient temperature and ensure that it is within the permissible operating limits.
- Do not store flammable materials in the immediate vicinity of the unit.

 **WARNING****Risk of overheating and fire due to blocked ventilation openings!**

Blocked ventilation openings or heat dissipation systems during operation can lead to overheating, damage to equipment, fire or reduced performance.

- Keep ventilation openings and heat dissipation systems clear.
- Do not place any objects on or in front of the ventilation openings.
- Maintain the minimum distances in accordance with the manufacturer's specifications.
- Check regularly that the ventilation openings are dust-free and unobstructed.

Mechanical safety **DANGER****Risk of falling when working at height!**

Inadequate fall protection or a lack of personal protective equipment (PPE) when working at height can lead to serious injury or death from a fall.

- Wear suitable personal protective equipment when working at height.
- Observe applicable occupational health and safety procedures (e.g. DGUV, EN standards for fall protection).

 **WARNING****Danger due to unsuitable or damaged tools!**

Using damaged, untested or overloaded tools can lead to mechanical injuries, damage to equipment or fire.

- Before starting work, make sure that you have all the required tools.
- Only use the tools if they have been tested by an approved specialist organisation.
- Do not use the tools if:
 - There are visible signs of damage (e.g. scratches, cracks)
 - They did not pass the test
 - The test is overdue
- Only use the tools within the permissible load range.
- Carry out regular inspections and document results in accordance with internal safety procedures.

 **WARNING****Risk of crushing and other injuries due to falling or sliding parts!**

Unstable or heavy objects in the cabinet may fall or slide around when the unit is removed. This can lead to crushing and other injuries from falling parts or to property damage.

- Check the control cabinet for loose or heavy objects before removing the unit.
- Secure or remove unstable parts before moving the unit.
- Wear suitable personal protective equipment (a hard hat, gloves, safety boots).
- Use lifting aids for heavy equipment or seek assistance from a second person.

 **WARNING****Damage to equipment and impaired functionality due to drilling!**

Drilling holes in the unit can lead to loss of sealing integrity, reduced electromagnetic shielding, damage to components or cables, and short circuits caused by metal shavings.

- Do not drill holes in the unit or make any mechanical changes.
- If adjustments are necessary, only use manufacturer-approved procedures.
- Ensure that protective features, such as IP ratings and EMC shielding, are not compromised.
- Avoid metal shavings and foreign objects to prevent short circuits.

Unit safety **DANGER****Electric shock and risk of injury due to moving parts!**

Opening the doors of the energy storage system during operation can lead to electric shock or injuries from moving parts.

- Only open the doors of the energy storage system after the system has been completely switched off and de-energised.

 **DANGER****Risk of injury in the door opening area of the energy storage system!**

Being within the door opening area of the energy storage system during a malfunction can lead to serious injuries.

- Keep clear of the area around the energy storage system door and its opening area in the event of a unit failure.
- Maintain a safe distance from the energy storage system door until the fault has been rectified and the system has been made safe.

 **WARNING****Fire hazard if fire alarm is triggered!**

Triggering of the acoustic and visual fire alarm indicates a fire hazard. Staying in the location can lead to serious injuries, smoke poisoning or death.

- If the fire alarm is activated, evacuate the area immediately in an orderly manner.
- Follow the designated escape routes and go to the assembly point.
- To save time, leave personal items behind.
- Do not ignore the alarm, even if there is no visible fire.
- After evacuation, follow the instructions of the safety personnel.

 **DANGER****Risk of fire and explosion due to mechanical battery damage!**

High mechanical stress, crushing or puncturing of the battery can lead to a short circuit, fire, explosion or serious injury.

- Do not crush, puncture, drop or otherwise subject the battery to mechanical damage.
- Do not use any tools or equipment that could deform or perforate the battery.
- Only handle and install the battery according to the manufacturer's instructions.
- If the battery is visibly damaged, do not use it; instead, remove and dispose of it safely in accordance with the applicable procedures.

 **DANGER****Risk of chemical burns from leaking electrolyte!**

A breach of – or damage to – the battery may result in electrolyte leakage. Leaking electrolyte is harmful to the skin and eyes, and can lead to serious injury.

- Avoid contact with leaking electrolyte.
- In case of skin or eye contact, rinse immediately with plenty of water.
- Seek medical attention immediately.
- Do not use damaged or breached batteries and dispose of them safely in accordance with applicable procedures.

 **DANGER****Risk of poisoning and damage to health from leaking battery electrolyte and gases!**

Toxic and volatile battery electrolyte – as well as liquids, gases or fumes released in the event of leakage or unusual odours – can cause serious injury, poisoning or adverse health effects if inhaled or upon contact.

- Maintain a safe distance from the battery and inform specialist personnel immediately.
- Work is only to be carried out by specialist personnel.
- Wear appropriate personal protective equipment: safety goggles, rubber gloves, a respirator and protective clothing.
- Isolate the unit from the power supply, remove the battery and inform qualified specialist personnel.

 **DANGER****Risk of fire, explosion and damage to health from a mechanically damaged battery**

Mechanical damage to the battery, e.g. caused by falling, can lead to internal damage, short circuits, overheating or electrolyte leakage. This can cause severe injuries, fire or explosion.

- Switch off the battery immediately.
- Stop using the battery.
- Maintain a safe distance from the battery and contact specialist personnel.
- Other measures are only to be carried out by qualified specialist personnel.

 **DANGER****Risk of fire and explosion due to sources of fire, flammable materials or sunlight!**

Exposing the battery to sources of fire, to flammable, explosive or chemical materials or to direct sunlight can lead to overheating, fire or explosion.

- Keep the battery away from sources of fire as well as flammable, explosive and chemical materials.
- Do not expose the battery to direct sunlight.
- Only operate and store the battery within the permissible environmental and temperature ranges.

 **DANGER****Risk of short circuit and electric shock due to conductive objects!**

Contact between the battery and conductive objects or touching exposed wires can result in short circuits, sparking, overheating, fire or injury.

- Keep the battery away from conductive objects.
- Do not touch exposed wires.
- To prevent the risk of short circuits, use appropriate covers and ensure correct handling.

 **DANGER****Risk of electric shock and burns due to high short-circuit current!**

A high short-circuit current and touching the battery with wet hands can lead to serious injuries, burns or electric shocks.

- Never touch the battery with wet hands.
- Keep the battery away from children and animals.
- In the event of damage, switch the unit off immediately.
- Inform specialist personnel immediately.

 **DANGER****Risk of damage to equipment and fire due to improper handling of the battery!**

Water, high voltage, improper positioning or mechanical stress on the battery can lead to a short circuit, overheating, fire or mechanical damage.

- Keep the battery dry.
- Do not expose the battery to inadmissible voltage.
- Place the battery on a flat, stable surface.
- Do not put anything on top of the battery.
- Do not subject the battery to mechanical loads.

⚠ WARNING**Risk of fire during battery installation and operation!**

There is a risk of fire when installing and operating the battery. Missing or unsuitable fire extinguishing agents can lead to severe material damage or injuries in the event of a fire.

- Provide and install suitable fire extinguishing agents (e.g. fire sand, CO₂ fire extinguishers) before installation and commissioning.
- Comply with building regulation requirements and all applicable local laws and regulations.
- Ensure that fire extinguishing agents are accessible and ready for use at all times.

⚠ WARNING**Risk of overheating and fire due to loose screw connections!**

Loose screw connections on copper busbars or cables can lead to excessive voltage drops, overheating or fire at high currents.

- Tighten screw connections to the specified torque.
- Check screw connections regularly for tightness and for rust, corrosion and foreign objects.
- If there are any noticeable problems, clean the contact surfaces and tighten the screw connections accordingly.
- Comply with the manufacturer's specifications as well as applicable standards and maintenance intervals.

⚠ WARNING**Battery damage due to deep discharge!**

Deep discharge due to delayed charging can lead to permanent battery damage and invalidate the guarantee.

- Charge the battery immediately after discharge.
- If the state of charge (SOC) reaches 0%, charge the battery within seven days to prevent damage.

2.3 Symbols on the unit

General warning sign



Warning – explosive substances



Warning – electric voltage



Warning – corrosive substances



Warning – hazards due to charging batteries



Warning – electric arcs



No naked flames, fires or open sources of ignition and no smoking



No climbing



No entry for children



Follow the manual



Wear protective footwear



Wear protective gloves



Wear protective clothing



Wear a face shield



Remaining time indicator: After switching off the system, wait five minutes before touching any parts.

2.4 Appropriate use

The TESVOLT FORTON energy storage system is designed exclusively for use as an industrial and commercial energy storage system. The system – comprising an energy storage system and a battery inverter – may only be operated in accordance with the specified technical specifications and operating conditions.

Applications

- For storing and providing electrical energy, for example in conjunction with photovoltaic, wind power or other energy generation systems.
- For optimising self-consumption or peak shaving in industrial and commercial applications.
- For connection to the TESVOLT Energy Manager for controlling and optimising energy consumption.

Prohibited use

- Not to be used outside the intended ambient conditions (e.g. do not use in extreme temperatures, in high humidity or in corrosive environments).
- Not suitable as a direct power source for vital medical devices or critical control systems.
- Not to be used in potentially explosive atmospheres or in the immediate vicinity of flammable materials.
- System components must not be altered or modified by unauthorised individuals.

Responsibilities of the operating company

- Ensure that the energy storage system is installed, operated and maintained by trained specialist personnel only.
- Carry out regular inspections and maintenance according to the manufacturer's specifications.
- Comply with all legal regulations and safety standards for using battery storage systems.

3 Product information

3.1 Scope of delivery

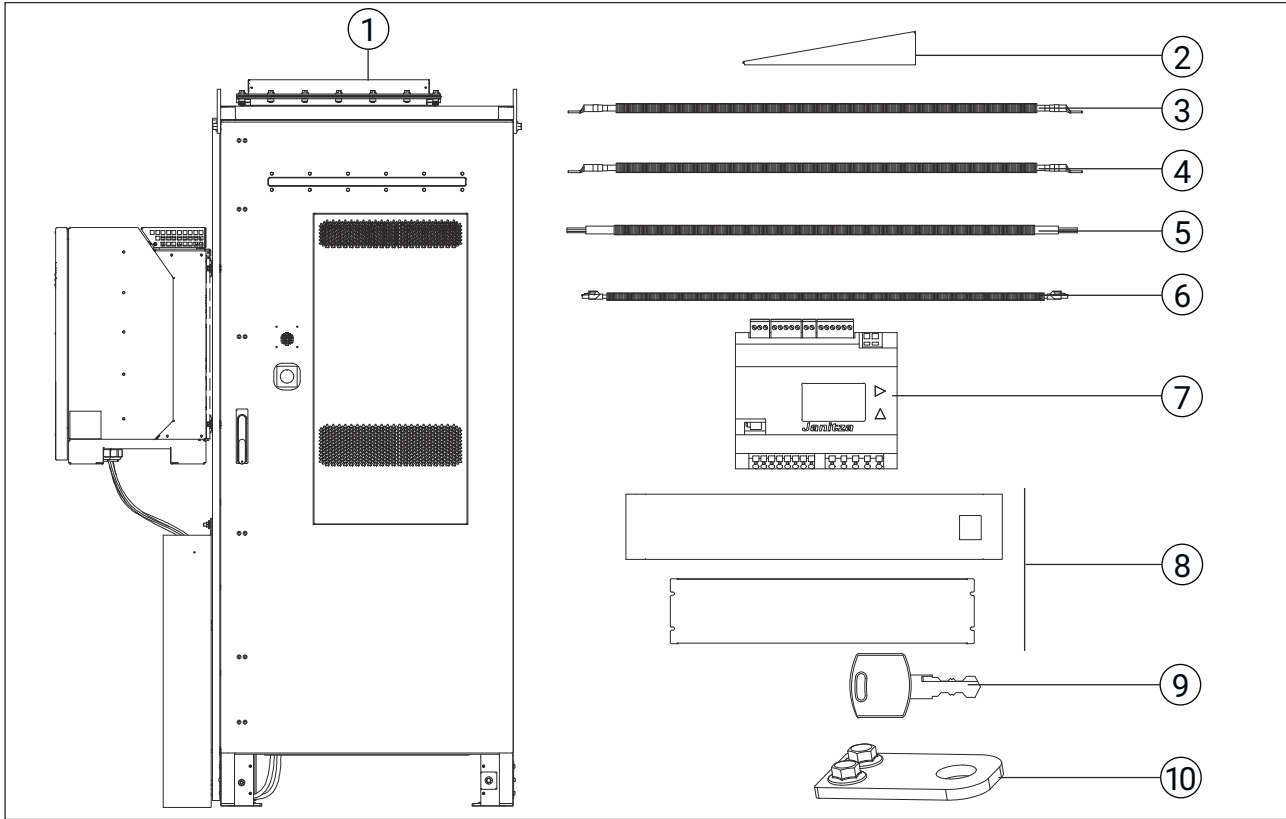

Fig. 1: TESVOLT FORTON scope of delivery

Item no.	Quantity	Description	
1	1	Main cabinet for TESVOLT FORTON energy storage system with KACO blueplanet gridsave 92.0 – 137 TL3-S battery inverter (optionally with EMS)	
2	1...	Weather canopy	
3	-	Cabinet connector set (optional)	DC cable ⊕
4	-		DC cable ⊖
5	-		AC AUX cable
6	-		Communication cable
7	1	Janitza UMG 604-Pro power analyser	
8	1...	Base cover	
9	1...	Key	
10	4	Transport lugs with screws	
-	-	TESVOLT FORTON 92 kWh extension cabinet (optional; without EMS)	

3.2 Product overview

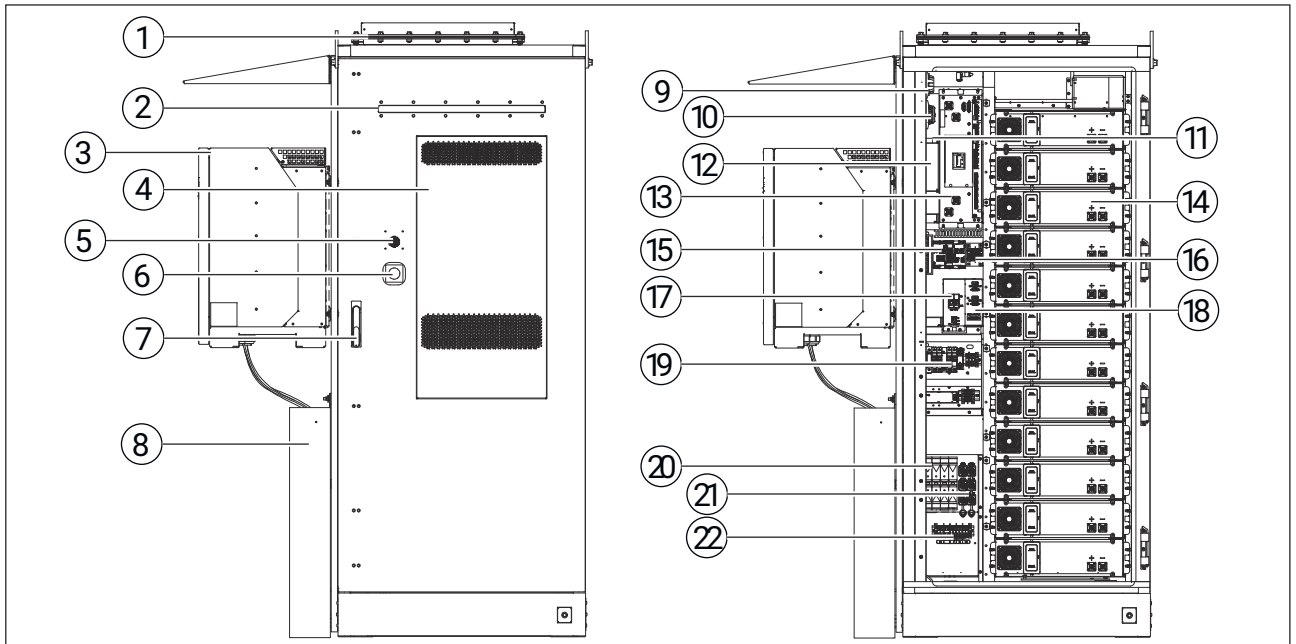

Fig. 2: Overview of the TESVOLT FORTON product

Item no.	Name
1	Explosion protection bursting disc
2	LED display
3	KACO blueplanet gridsave 92.0 TL3-S battery inverter
4	Heat exchanger, air-cooled
5	Acoustic signal generator, triggered in case of a fault
6	Emergency stop button (E-stop)
7	Door lock
8	Cable cover
9	Smoke sensor
10	Temperature sensor
11	Gas sensor (CO)
12	Aerosol fire extinguishing unit
13	High-voltage unit (HV unit)
14	Battery module
15	TESVOLT IoT gateway
16	TESVOLT Energy Manager
17	Uninterruptible power supply (UPS)
18	Connection for uninterruptible power supply (UPS)

Item no.	Name
19	Back-up fuses
20	DC connections
21	Communication connections
22	AC AUX connections

3.3 Battery module connections

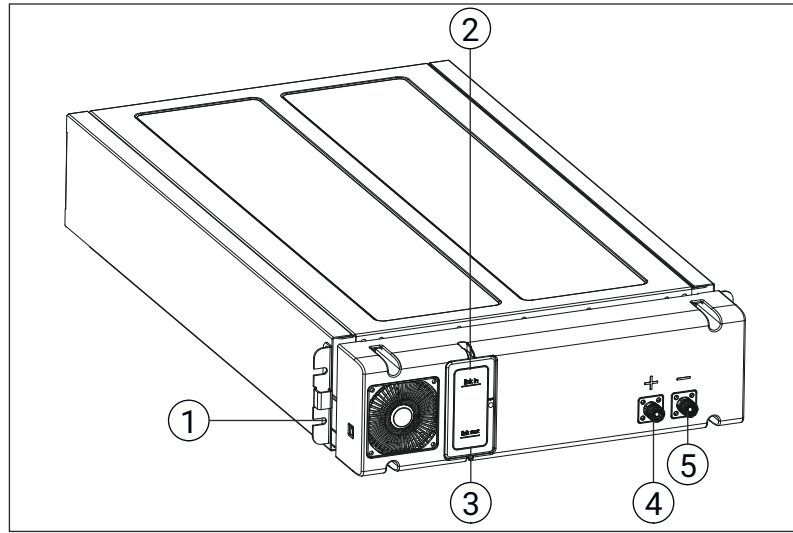

Fig. 3: Battery module connections

Item no.	Designation	Description
1	Fastening tabs	For fixing and grounding (with protective coating)
2	Link In	Communication connection for the previous battery module or HV unit
3	Link Out	Communication connection for the subsequent battery module or termination connector
4	⊕	Positive pole, positive output of the battery module
5	⊖	Negative pole, negative output of the battery module

3.4 Connections and layout of the high-voltage unit (HV unit)

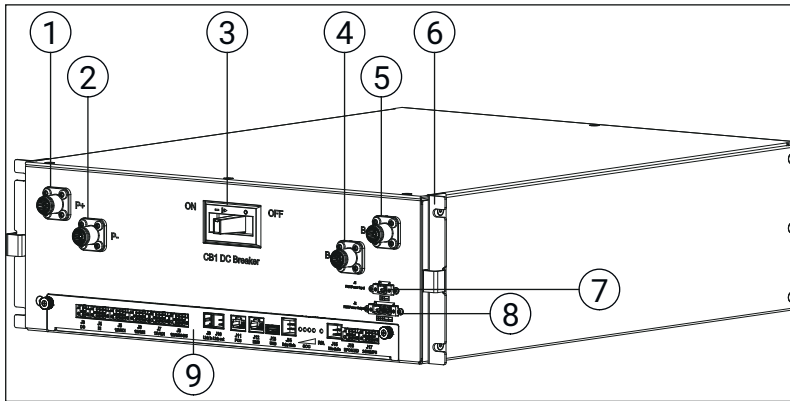

Fig. 4: High-voltage unit connections

Item no.	Name	Description
1	P+	Positive output connection between energy storage system and battery inverter
2	P-	Negative output connection between energy storage system and battery inverter
3	DC circuit breaker	Main switch for the battery module's DC circuit and switch for the module's own power supply
4	B-	Negative input connection between HV unit and battery module
5	B+	Positive input connection between HV unit and battery module
6	Fastening tabs	For fixing and grounding (with protective coating)
7	J1, fan power input	External power input connection for the battery module fans (24 V _{DC})
8	J2, fan power output	Power output connection for the battery module fans (24 V _{DC})
9	BCU board	Battery cluster unit (BCU) – control unit for the battery module string

BCU (battery cluster unit) board connections

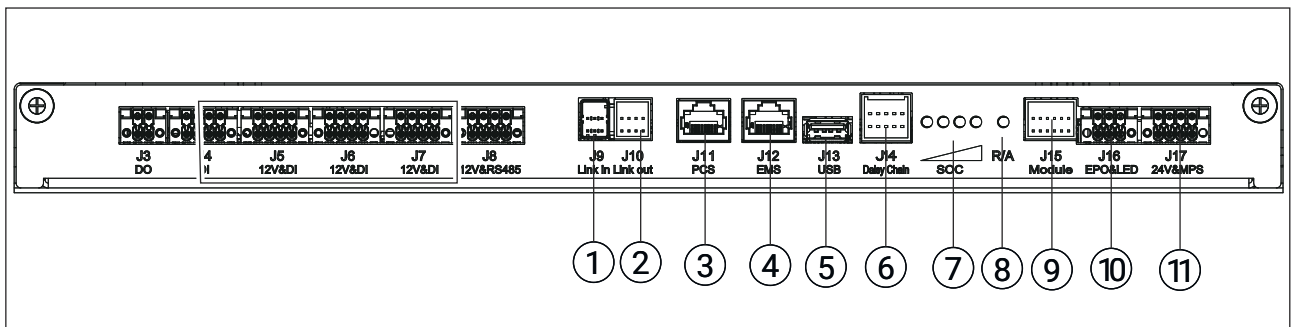

Fig. 5: BCU board connections

Item no.	Name	Description
1	J9 Link In	Communication input for parallel connection
2	J10 Link Out	Communication output for parallel connection
3	J11 PCS	Communication connection with PCS (power conversion system) or DC-DC converter
4	J12 EMS	Communication connection to EMS (energy management system) and wake-up signal for energy-saving mode (12 V _{DC})
5	J13 USB	Connection for software updates and data exports
6	J14 Daisy Chain	Connection for daisy-chain communication with module
7	SOC	LED state of charge (SOC) indicators
8	R/A	LED indicator for operating status and alarms
9	J15 Module	Communication and power connection for the battery module
10	J16 EPO&LED	Emergency stop (emergency power off, EPO) and LED indicator connection for the cabinet casing
11	J17 24V&MPS	External 24 V _{DC} power supply connection and UPS power input connection

3.5 External connecting terminals

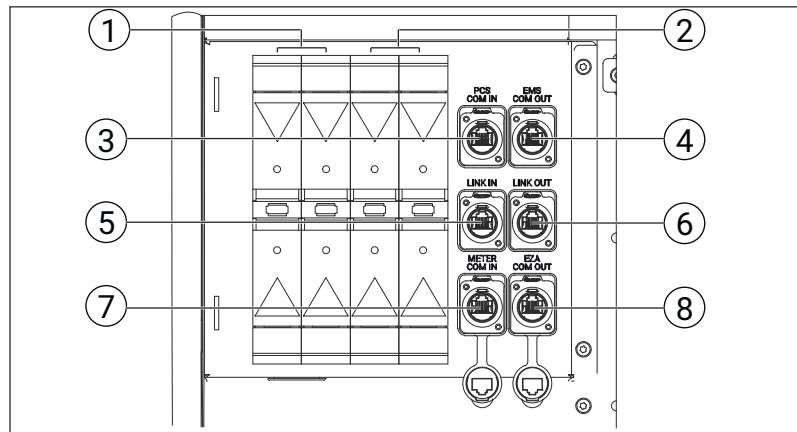

Fig. 6: External connecting terminals

Item no.	Name	Description
1	Positive DC terminals	For connecting the DC cables from the battery inverter to the energy storage system and the DC cables between energy storage systems.
2	Negative DC terminals	
3	PCS COM IN	Battery inverter communication input
4	EMS COM OUT	EMS communication output for use in conjunction with the Control Center
5	LINK IN	Parallel BMS communication input connected to the LINK OUT of the previous energy storage system. The first energy storage system must have a terminating resistor.
6	LINK OUT	Parallel BMS communication output for use in conjunction with the LINK IN of the next energy storage system. The last system must have a terminating resistor.
7	METER COM IN (optional)	External meter communication input
8	EZA COM OUT (optional)	EMS communication output for use in conjunction with the EZA controller

3.6 Aerosol fire extinguishing system

3.6.1 Overview

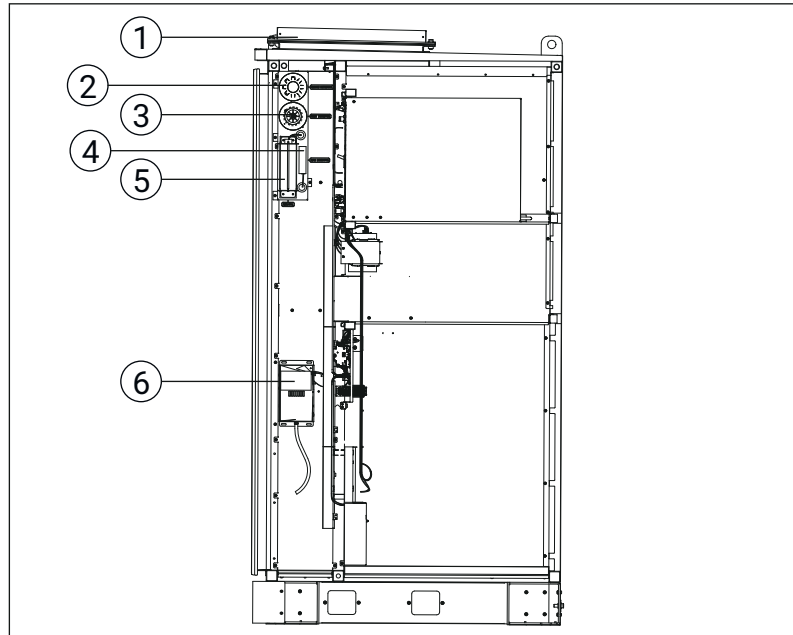

Fig. 7: Overview of the aerosol fire extinguishing system

- [1] Explosion protection bursting disc
- [2] Smoke sensor
- [3] Temperature sensor
- [4] Aerosol
- [5] Gas sensor
- [6] Dehumidifier

3.6.2 Functional principle

A fire breaks out.		
Smoke is generated/the temperature rises		
The smoke sensor responds.		The temperature sensor responds.
A smoke alarm is sent to the BMS/EMS.		A temperature alarm is sent to the BMS/EMS.
First alarm		
Second alarm: The BMS/EMS activates an acoustic and visual alarm.		
The BMS/EMS activates the aerosol extinguishing system.		
The fire extinguishing agent is released. The BMS receives a confirmation.		
The fire is extinguished.		

3.7 Environmental control system

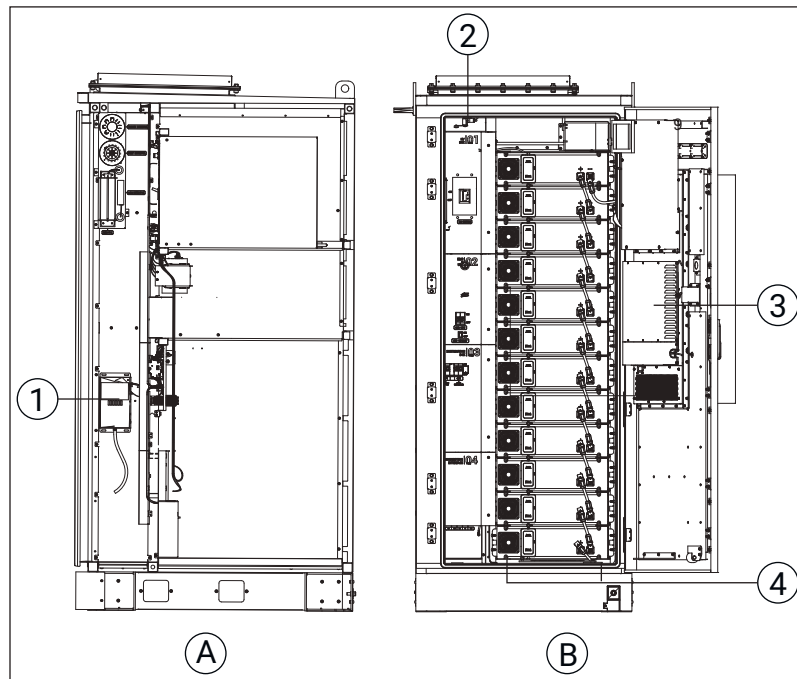
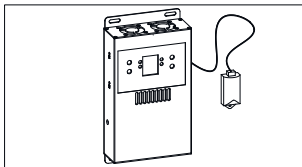

Fig. 8: Components of the environmental control system

- [A] Side view
- [B] Front view with the door open
- [1] Dehumidifier
- [2] Access sensor
- [3] Heat exchanger
- [4] Water sensor

Dehumidifier



Name	Description
Input voltage	24 V DC
Dehumidification power consumption	60 W
Humidity measurement range	20...95% RH (accuracy $\pm 3\%$ RH)
Dehumidification value	45...95% RH adjustable, default value 60% RH
Dehumidification efficiency	500 \pm 10 ml/day (35°C, 85% relative humidity)
Temperature measurement range	-25...95°C (accuracy $\pm 1^\circ\text{C}$)
Operating temperature	0...55°C
Dimensions (H x W x D)	235.6 mm x 125.0 mm x 46.0 mm
Weight	1.32 kg
Casing material	Aluminium alloy

Access sensor

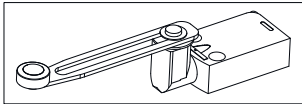

Name	Description
Type	Body (fixed) and swivel head (rotating)
Swivel head	Spring return roller, variable length
Material	Zamak alloy
Alarm signal	2 channels (1 NC + 1 NO)
Minimum opening force	0.5 N

Heat exchanger

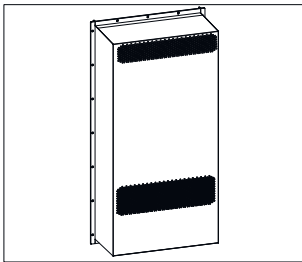

Name	Description
Input voltage	176...264 V AC, single-phase
Heat dissipation capacity	150 ± 10% W/K
Heating output	1,500 W
Operating current	1.4 A (heating 7.8 A)
Operating current consumption	308 W (heating 1,716 W)
Operating temperature	-40°C...65°C
Volume	Max. 73.5 dB(A) at full speed
Dimensions (H x W x D)	947 mm x 487 mm x 303 mm
Weight	39 kg

Water sensor

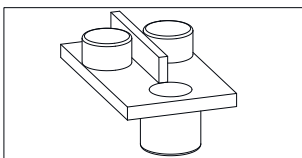

Name	Description
Electricity supply	12 V DC ± 5%
Alarm threshold	50 kΩ ± 10 kΩ (stagnation value ≥ 5 kΩ)
Working current	Without water < 15 mA; alarm < 33 mA
Alarm signal	2 channels (1 NC + 1 NO)
Operating temperature	0°C...60°C
IP protection class	IP65

3.8 Dimensions

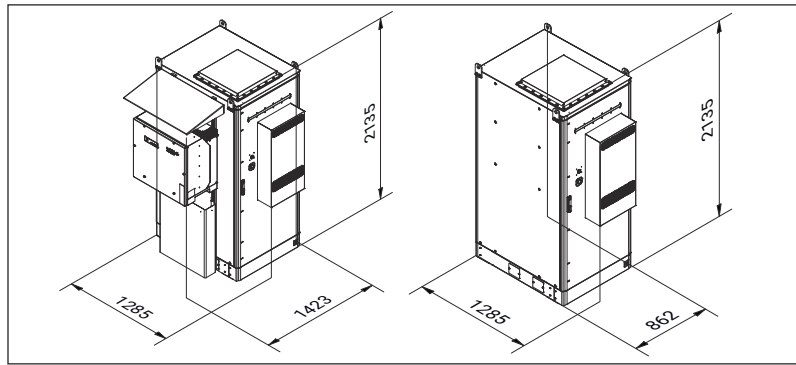

Fig. 9: Dimensions with battery inverter and replacement energy storage system [mm]

Design	Width [mm]	Height [mm]	Depth [m]
Energy storage system with battery inverter	1423	2135	1285
Energy storage system without battery inverter	862	2135	1285

3.9 Technical Data

3.9.1 Technical data for the energy storage system

Name	TESVOLT FORTON
Type designation	FORTON/12-30
Energy content (at 100% DoD)	92 kWh
Maximum charging/discharging power	92 kW
Nominal voltage	921.6 V _{DC}
Operating voltage	806.4...1036.8 V _{DC}
Max. C-rate	1C
Max. auxiliary energy consumption in heating mode	2 kW
Max. auxiliary energy consumption in cooling mode	300 W
Average auxiliary energy consumption (example)	200...250 W
Cell chemistry	LFP, high temperature
Cooling	Heat exchanger, air-cooled
Altitude of installation site	< 3000 m above sea level

Name	TESVOLT FORTON
Ambient temperature	-20...55°C
Humidity	5...95% (non-condensing)
Weight (not including battery inverter)	1400 kg
Dimensions (H x W x D, not including battery inverter)	2100 mm x 860 mm x 1300 mm
Noise emission (not including battery inverter)	60 dB (A)
Protection class	IP55
Paintwork	C4
Certification	CE, VDE-AR-E 2510-50:2017 (battery module), IEC 61000-6-2:2019, IEC 61000-6-4:2019, IEC 61000-6-7:2015, UN38.3 Rev.8, IEC 62619:2022, IEC 62477-1:2022, IEC 61000-6-1:2019, IEC 61000-6-3:2021, UL9540A (cell)

3.9.2 Technical data for the battery

Name	Battery
Total capacity/power	100 Ah/7.68 kWh
Capacity/power	98 Ah/7.52 kWh
Nominal voltage	76.8 V
Output voltage range	67.2...86.4 V
Max. charging/discharging power (at 25°C)	7.68 kW
Peak charging/discharging power (at 25°C)	9.0 kW/5 s
Certification	CE, VDE-AR-E 2510-50:2017, IEC 62619:2022, UL9540A, UN 38.3 Rev.8
Protection class	IP20
Operating temperature range	0...55°C
Optimum operating temperature	15...30°C
Humidity	5...95% (non-condensing)
Storage conditions	7 days: at -20...-30°C or 45...60°C and 5...95% air humidity
	6 months: at -20...45°C and 5...95% air humidity
Dimensions without fastening tabs (H x W x D)	129 mm x 442 mm x 777 mm
Altitude of installation site	< 3000 m above sea level

Name	Battery
Weight	61 kg
Serial connection/voltage difference between the modules	$\Delta V \leq 1 \text{ V}$
Connection	1 parallel, 24 series (1P24S)
Capacity on delivery	30% SoC

3.9.3 Technical data for the KACO battery inverter

Name	KACO BLUEPLANET GRIDSAVE 92.0 TL3-S
DC input	
Operating voltage	668...1315 V _{DC}
Max. input current	145 A
AC output	
Nominal power	92000 VA
Maximum power	92000 VA
Nominal voltage	400 V
Voltage range (phase-to-phase)	300...580 V
Nominal frequency (range)	50 Hz/60 Hz (45...65 Hz)
Nominal current	3 x 132.3 A
Maximum current	3 x 132.3 A
Reactive power / cos φ	0...100% S _{max} /0.30 ind. -0.30 cap.
Total harmonic distortion (THD)	< 3 %
Number of feed-in phases	3
General data	
Max. efficiency	Charging: 98.5%
	Discharging: 98.7%
Operating mode	Grid-connected (charge/discharge)
Self-consumption in stand-by mode	< 8 W without PCU, < 14 W with PCU relay closed
Protective functions	Overvoltage, overcurrent, overload, undervoltage
Wiring concept	Transformerless
Mechanical data	
AC connections	Screw terminals, max. 240 mm ² Cu or Al
Ambient temperature	-20...60°C

Name	KACO BLUEPLANET GRIDSERVE 92.0 TL3-S
Humidity	0...100%
Altitude of installation site	< 3000 m above sea level
Cooling	Temperature-controlled fan
Protection class	IP66/NEMA 4X
Noise emission	< 60 dB (A)
Dimensions (H x W x D)	719 mm x 699 mm x 450 mm
Weight	80 kg
Certification	
Safety	IEC 62477-1:2012, IEC 62109-1/2

3.10 Type plate

TESVOLT		Rechargeable Lithium-Ion Industry-Battery System Wiederaufladbares Lithium-Ionen Industriebatteriesystem					
Model / Modellbezeichnung	<input type="checkbox"/> FORTON/7-30	<input type="checkbox"/> FORTON/8-30	<input type="checkbox"/> FORTON/9-30	<input type="checkbox"/> FORTON/10-30	<input type="checkbox"/> FORTON/11-30	<input type="checkbox"/> FORTON/12-30	
Battery Designation / Batteriekategorie	IfpP24/125/364 [(24S)730] E/0460/100	IfpP24/125/364 [(24S)860] E/0460/100	IfpP24/125/364 [(24S)950] E/0460/100	IfpP24/125/364 [(24S)1050] E/0460/100	IfpP24/125/364 [(24S)1150] E/0460/100	IfpP24/125/364 [(24S)1230] E/0460/100	
Battery Type / Chemische Zusammensetzung	Lithium-Iron-Phosphate (LiFePO ₄) / Lithium-Eisen-Phosphat (LiFePO ₄)						
Total/Rated Capacity / Total-/Nennleistungskapazität	100Ah / 98Ah						
Weight / Gewicht	Max. 895 kg	Max. 956 kg	Max. 1017 kg	Max. 1078 kg	Max. 1139 kg	Max. 1200 kg	
Nominal Voltage / Nennspannung	537.6Vdc	614.4Vdc	691.2Vdc	768Vdc	844.8Vdc	921.6Vdc	
Charge/Discharge Voltage Range / Lade-/Entladespannungsbereich	478.8–604.8 Vdc	547.2–691.2 Vdc	615.6–777.6 Vdc	684.0–864.0 Vdc	752.4–950.4 Vdc	820.8–1036.8 Vdc	
Max. Charge/Discharge Power / Max. Lade-/Entladeleistung	53.76 kW	61.44 kW	69.12 kW	76.80 kW	84.48 kW	92.16 kW	
Operating Temp. Range / Arbeitstemperaturbereich	-20°C–55°C						
Max. Charge/Discharge Current / Max. Lade-/Entladestromstärke	100 Adc						
Capacitor Discharge / Kondensatorentladung	5 min						
Protection Type / Schutzart	IP 55						
Protection class / Schutzklasse	I						
Recommended Charging Instruction / Empfohlene Ladeanweisung	CC-CV CP						
Fire Extinguishing Agent / Feuerlöschmittel	Water / Wasser						
TESVOLT AG Am Heideberg 31 06506 Lützenstadt Wittenberg Deutschland info@tesvolt.com www.tesvolt.com Place of Factory: Made in China by / Hergestellt in China von Amproce							
							

Fig. 10: TESVOLT FORTON type plate

The type plate is located on the inside of the energy storage system door.

4 Transport

4.1 Transport to the end customer

DANGER

Risk of injury due to improper transport in a vehicle!

Improper transport and/or inadequate transport locks can cause the load to slide or topple over.

- Position the energy storage system vertically and in such a way that it cannot slide around in the vehicle. Also use securing straps to prevent it from toppling over and sliding.

CAUTION

Risk of injury due to failure to wear safety boots!

If hazards occur, there is a risk of injuries – due to crushing, for example – as a result of the components' heavy self-weight when the energy storage system is being transported.

- Wear safety boots with protective toe caps.

NOTICE

Material damage due to improper transport!

Improper transport can damage the energy storage system and its components.

Proceed as follows to prevent damage to the energy storage system:

- Pay attention to the energy storage system's centre of gravity.
- Do not tilt the system by more than 5°.
- Do not move the system in a jerky manner.
- Do not store the system in the packaging for longer than 6 months.
- Do not stack energy storage systems or place anything on top of them.
- Observe the fire protection requirements.

Regulations

All the requirements set out in the German Federal Ordinance on the Transport of Dangerous Goods by Road, Rail and Inland Waterways (GGVSEB) and the European Agreement Concerning the International Carriage of Dangerous Goods by Road (ADR) must be adhered to.

Transport authorisation

- Only the manufacturer or a contracted haulier is authorised to transport the system.
- Only trained and briefed personnel are permitted to transport the system on public roads.
- Briefings must be documented and repeated regularly.

Safety precautions

- Smoking is prohibited in the transport vehicle and during loading and unloading.
- Two tested metal fire extinguishers (fire class D, min. 2 kg) must be carried on the vehicle.
- Dangerous goods equipment in accordance with the ADR is required.

Packaging

The freight carrier is **prohibited** from opening the outer packaging of the energy storage system.

Loading/unloading and transport

The energy storage system is transported by lorry and can be unloaded using a forklift, or optionally with a crane.

Unloading at the construction site

- The thoroughfares for the lorry must be checked to ensure that they are sufficiently wide.
- The substrate must be suitable for lorries to ensure the necessary load-bearing capacity.
- Optionally, the system can also be set up directly at the installation site using a lorry crane.
- The substrate that the energy storage system is set down on must be able to support its total weight.
- Check for transport damage after delivery and report any issues identified to TESVOLT.

4.2 Transport at end-customer site**Safe and secure transport**

To transport the energy storage system over a short distance, we recommend using a manual pallet truck/forklift, lifting it from the rear and maintaining a maximum transport speed of 5 km/h.

Regardless of the method of transport used, the following points must always be taken into account:

- The position of the centre of gravity
- The size and the weight
- Safety of the machine operator

Transport by forklift

If a forklift is used for transport, the following points must be observed:

- The load capacity of the forklift must be ≥ 1.5 t.
- The recommended fork blade length is ≥ 1100 mm.
- Keep the forks at a height of 10...30 cm above the ground.
- If the foundation is ≤ 0.3 m high, the height must be adjusted accordingly.

Transport by crane

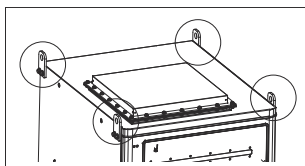

Before transporting by crane:

- ▶ Attach all 4 transport lugs.

The following points must be observed during transport:

- The crane and lifting ropes must meet the load capacity requirements.
- Lifting operations may only be performed by trained and certified personnel.
- The cabinet doors must be closed and locked.
- No-one is allowed under the crane boom during lifting.
- The maximum permissible tilt during lifting is $\leq 5^\circ$.
- The maximum permissible angle between the lifting ropes is $\leq 90^\circ$.
- To prevent damage to its internal components, the system must be lowered slowly and evenly.
- Additional energy storage systems may only be moved once the first energy storage system has been properly secured.

After transporting by crane:

1. ▶ Remove all 4 transport lugs.
2. ▶ Use the screws to seal the holes for the transport lugs so that they are watertight.

4.3 Removing packaging

CAUTION

Risk of injury when cutting!

There is a risk of cutting injuries when opening the packaging.

- Wear protective gloves.
- Use a safety knife.

- ▶ Remove the packaging after transport and dispose of it properly.

4.4 Storage



If the system is stored for more than 10 months: Contact TES-VOLT Service.

If the energy storage system is not installed on site immediately after delivery and acceptance, it must be kept inside its outer packaging and stored in a clean, dry, well-ventilated room in accordance with the following storage requirements.

Tab. 1: Storage requirements

Temperature	Air humidity	Maximum storage period
-30...-20 °C or 45...60 °C	5...95%	7 days
-20...45°C	5...95%	180 days

5 Installation

CAUTION

Risk of burns due to short circuit!

If the module connectors are short-circuited, the heat generated by the current can cause burns.

- Wear personal protective equipment.

CAUTION

Risk of crushing due to slamming door!

There is a risk of fingers getting crushed when closing the door of the energy storage system.

- Use the latching function of the door.



Door latching function

During all work on the energy storage system, the door must be opened far enough for the single-position latch to engage. In this way, injuries and damage can be avoided.

To release the latch:

- *Position one foot under the latch and use it to lift the latch up.*

5.1 Required Tools

DANGER

Risk of electric shock due to non-insulated tools!

Using non-insulated tools can result in serious injury or electrocution.

- Only use tools with suitable insulation protection.
- Ensure that the black part of the tool is the insulation layer.
- Do not use damaged or insufficiently insulated tools.

DANGER

Risk of electric shock and injury during installation!

Failure to wear suitable personal protective equipment or to keep electrical components switched off during installation can result in serious injury or electrocution.

- Before commencing installation, don suitable personal protective equipment (e.g. safety goggles, gloves).
- Ensure that all electrical components are switched off and de-energised.
- Work must always be performed in compliance with the applicable safety rules.

Tools and auxiliary equipment	Use
Ring/open-end spanner, size 16/17	For checking the fastening of the DC cable to the battery inverter
Ring/open-end spanner, size 13	For checking the fastening of the DC cable to the cabinet
Insulated hex key	Installation
Insulated screwdriver	
Insulated torque wrench	
Cable stripper	

5.2 Installation site

CAUTION

Risk of injury due to crushing!

When setting down and adjusting the energy storage system at the installation site, there is a risk of crushing injuries to the hands or feet.

- Wear personal protective equipment (e.g. work safety boots).

CAUTION

Risk of corrosion and malfunction due to damaged surfaces!

Damaged paint surfaces can lead to corrosion of metal parts, reduced protection, malfunctions or premature failure of the unit. In the long term, increased maintenance costs and safety risks may be incurred.

- Repair scratches and surface damage immediately using a suitable paint.
- Do not leave damaged areas unprotected for prolonged periods.
- Visually inspect surfaces regularly and document maintenance measures.

NOTICE

Material damage due to crushing!

There is a risk of crushing the pre-assembled cables when setting down and adjusting the energy storage system at the installation site.

- After putting the energy storage system in position, check the pre-assembled lines for crushing and insulation damage.

5.2.1 Installation conditions

The energy storage system is designed for operation at an ambient temperature of $-20...55^{\circ}\text{C}$. If the temperature of the battery module exceeds 45°C , the output power will be reduced. If the cell temperature is too low, the battery has to warm up before it can operate at full power. The intensity of solar radiation must be $\leq 1200 \text{ W/m}^2$. The energy storage system must not be installed in salty or dirty environments, as this can lead to corrosion.

The energy storage system can be used in the following environments:

- However, to prevent corrosion, the system must be located more than 10 km from the coast if used outdoors.
 - Installation of the system within 2...10 km of the coast is not recommended. If installation within this range is planned, TESVOLT must be consulted beforehand.

5.2.2 Installation plan

5.2.2.1 Installation area for a single-unit system

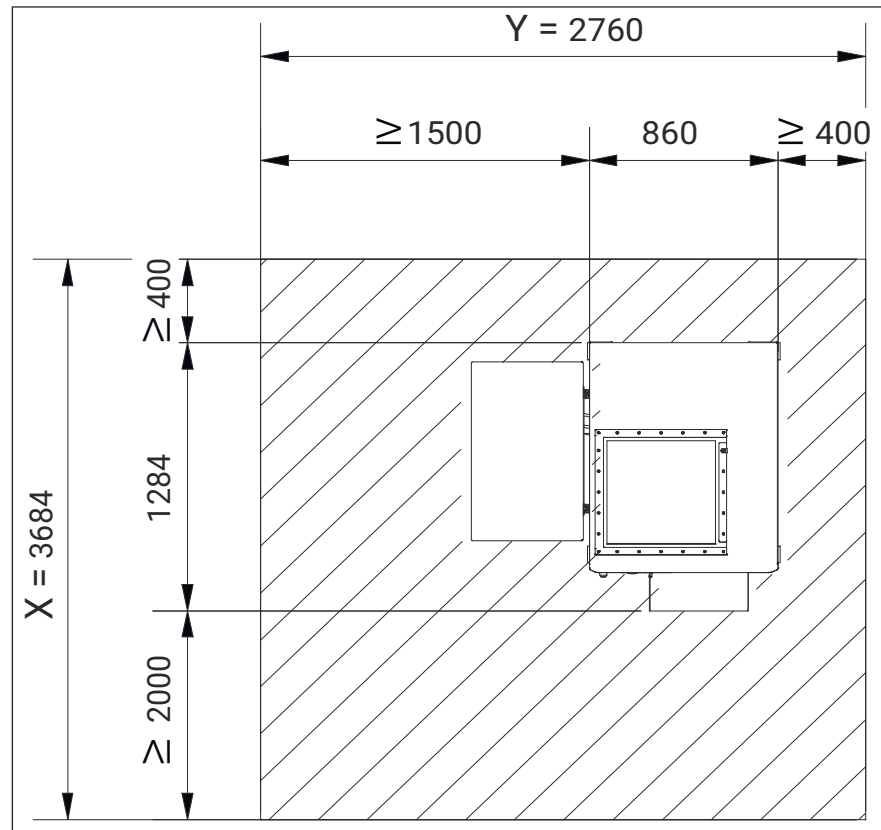

Fig. 11: Installation area [mm] for a single-unit system

5.2.2.2 Installation area for a multi-unit system

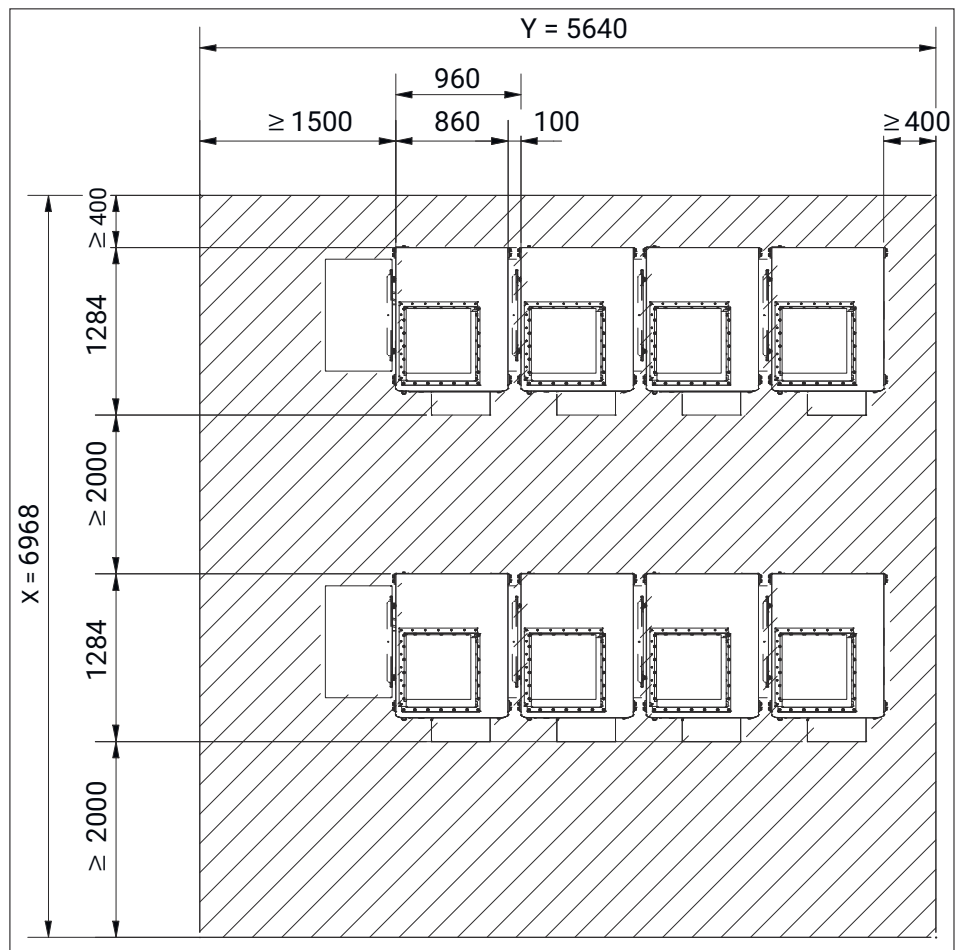

Fig. 12: Installation area [mm] for a multi-unit system, type 1

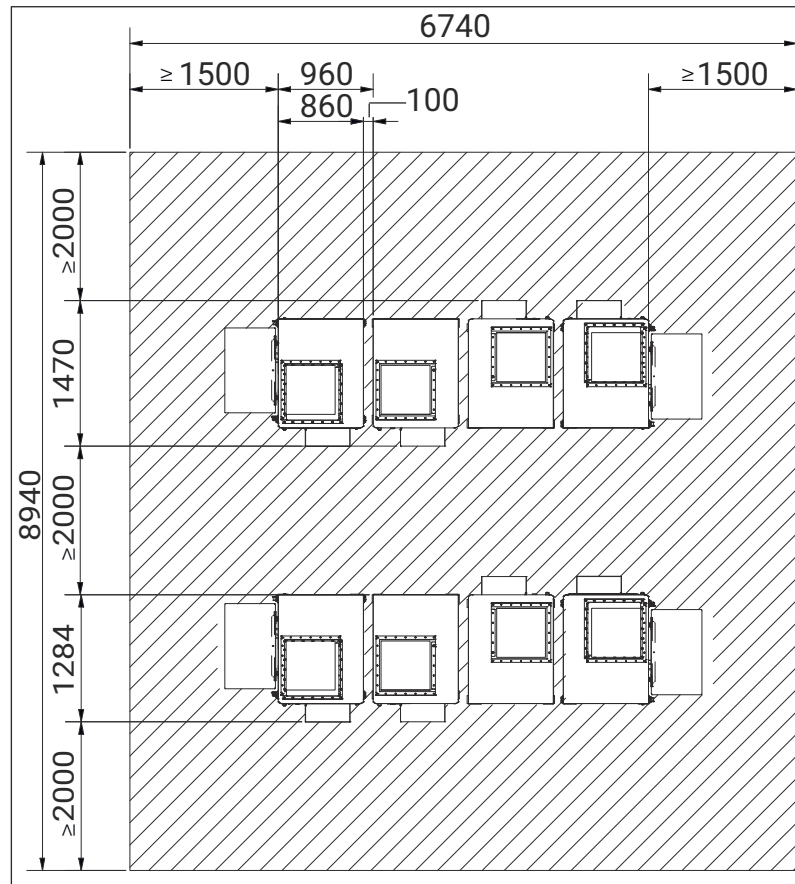

Fig. 13: Installation area [mm] for a multi-unit system, type 2

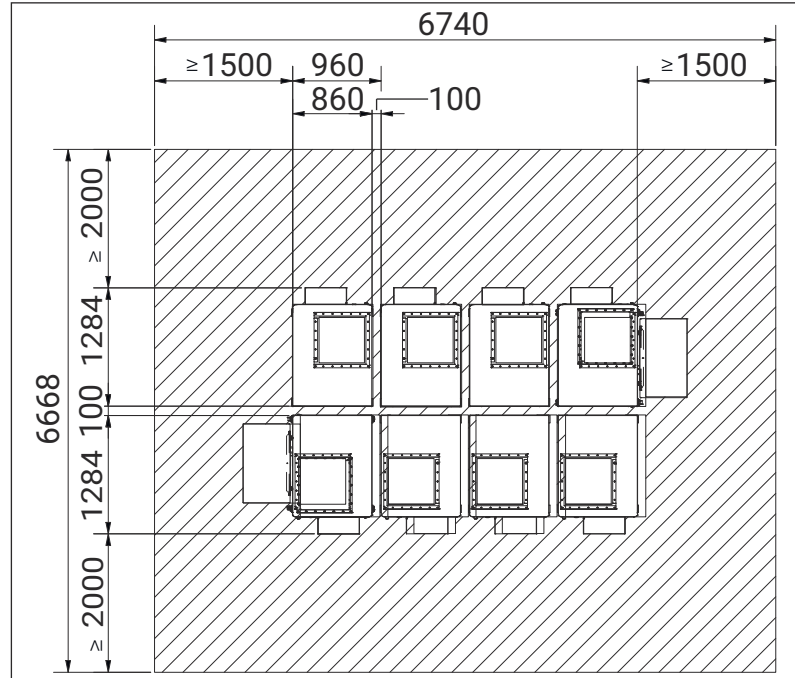

Fig. 14: Installation area [mm] for a multi-unit system, type 3

5.2.2.3 Installation area for a multi-unit system, block type

Configuration: 1472
kWh/368 kW

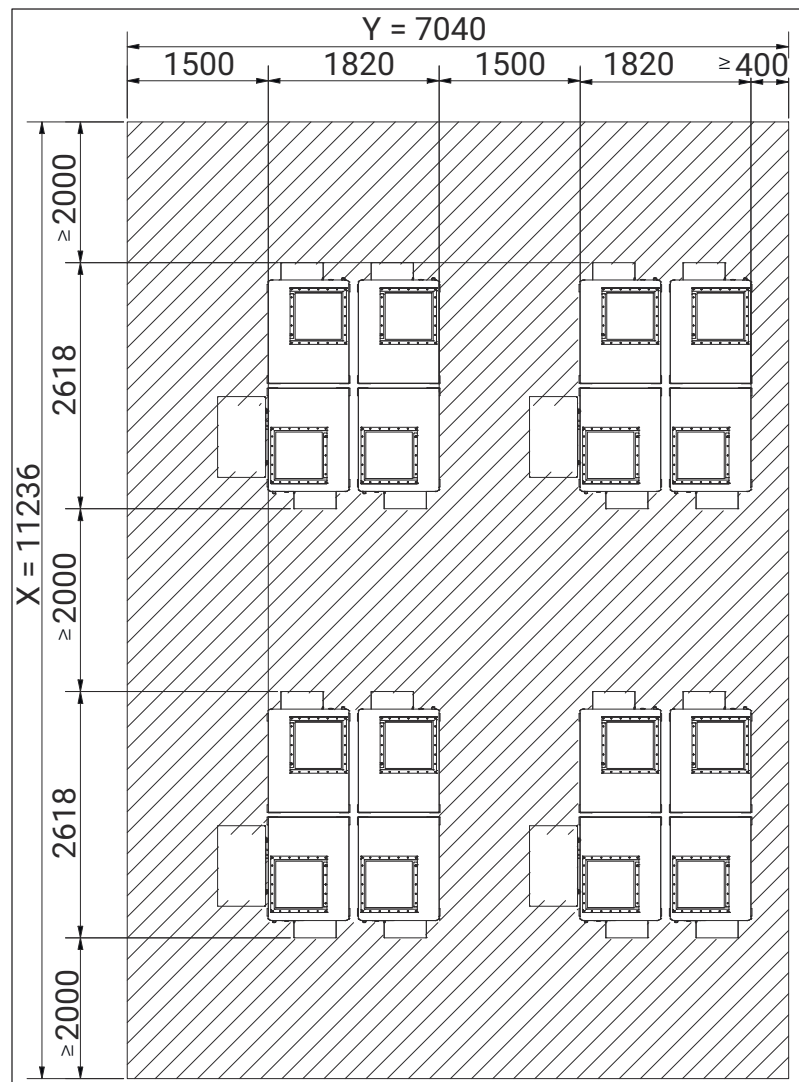

Fig. 15: Installation area [mm] for block type 1

**Configuration: 369
kWh/92 kW**

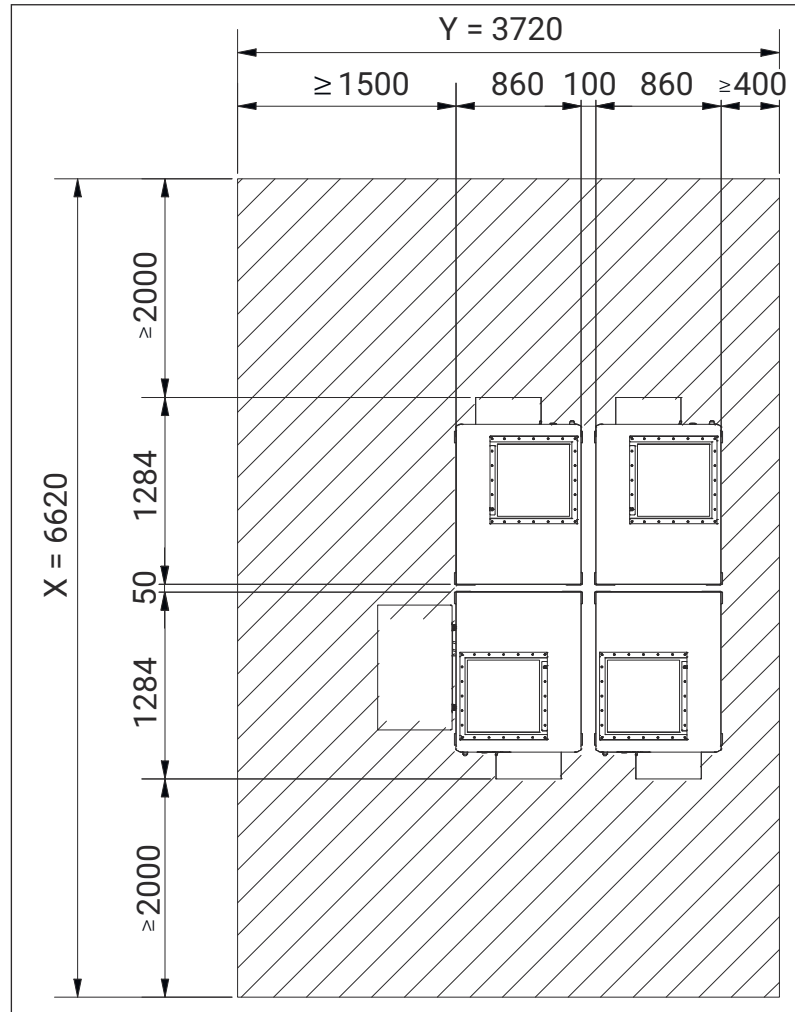

Fig. 16: Installation area [mm] for block type 2

5.2.2.4 Overview of configurations

Installation area				
Configuration [kWh]	Number of inverters	Number of cabinets	X [mm]	Y [mm]
92	1	1	3684	2760
184	1	2	3684	3720
276	1	3	3684	4680
369	1	4	3684	5640
184	2	2	6968	2860
369	2	4	6968	3720
553	2	6	6968	4680
737	2	8	6968	5640
276	3	3	10,252	2860

Installation area				
Configuration [kWh]	Number of inverters	Number of cabinets	X [mm]	Y [mm]
553	3	6	10,252	3720
829	3	9	10,252	4680
1106	3	12	10,252	5640
369	4	4	13,536	2860
737	4	8	13,536	3720
1106	4	12	13,536	4680
1475	4	16	13,536	5640

X = number of inverters x 3284 + 400

Y = number of cabinets in a row x 960 + 1800

5.2.3 Recommended minimum foundation areas

The information provided in this section is not a substitute for foundation planning and is merely intended to provide an overview. The foundation design depends on the ground conditions on site. The customer must have an inspection carried out by a structural engineer.

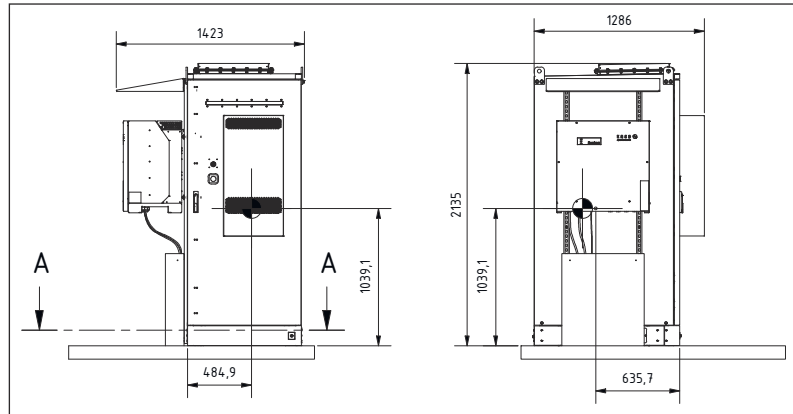

Fig. 17: Recommended minimum foundation areas [mm]

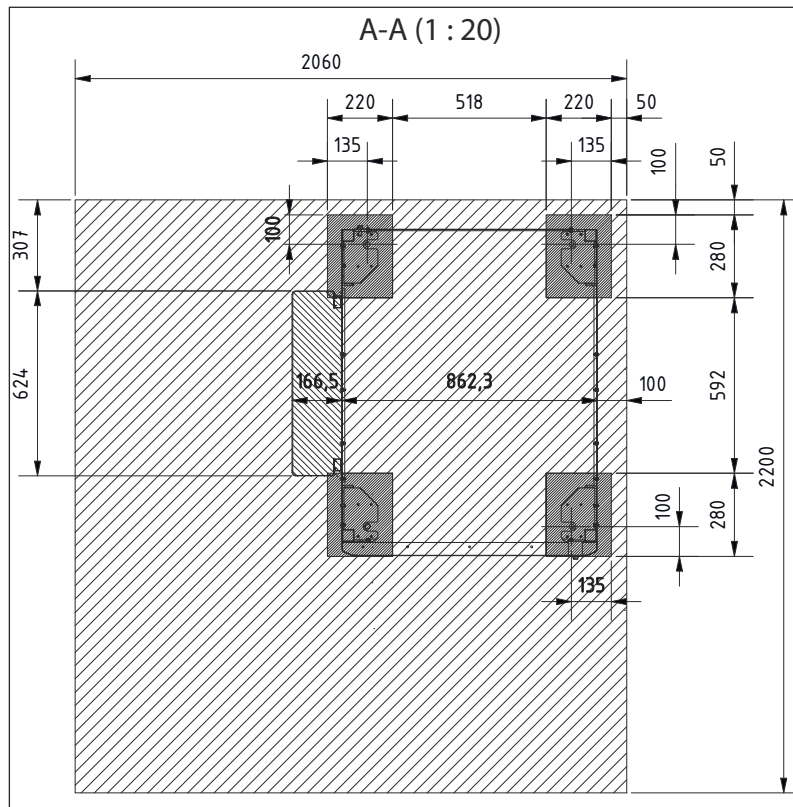





Fig. 18: Plan view [mm]

-  Recommended paved area
-  Area for cable feedthrough
-  Area load

Area for battery module exchange

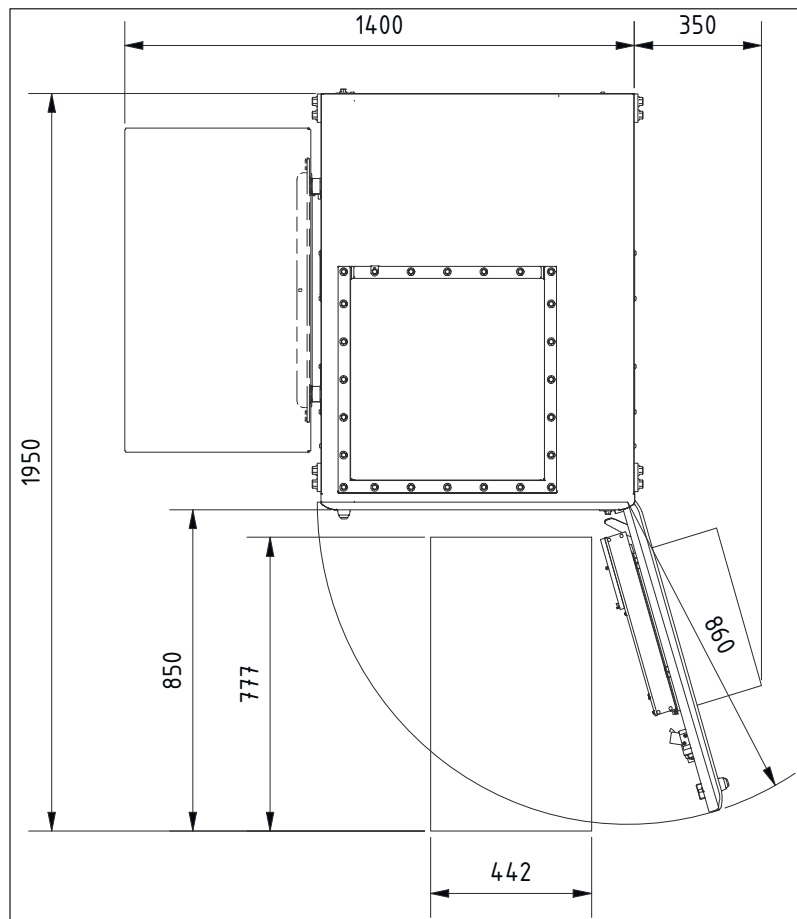

Fig. 19: Minimum area for battery module replacement

5.2.4 Connection anchor requirements

A suitable connection anchor is required to hold the energy storage system securely in the foundation. This anchor is not included in the scope of delivery. When installing the connection anchor, follow the manufacturer's instructions.

The following requirements apply to the connection anchor and installation:

- Clean the drill holes before installation.
- The concrete strength class must be C30.
- The tensile strength of the connection anchor must be at least twice the weight of the energy storage system.
- After installation, a pull-out test must be carried out.
- The anchoring area must not be allowed to overheat during welding work, as this can lead to failure of the reinforcement.
- The adhesion strength of adhesives for load-bearing structures must have been tested.

Example of a connection anchor

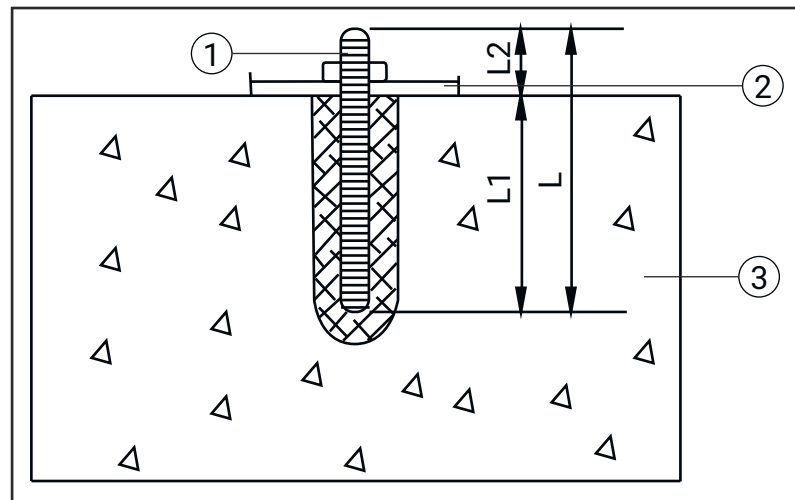

Fig. 20: Connection anchor

- [1] Anchor plate
- [2] Connection anchor
- [3] Concrete foundation

Connection anchor	Shear strength design value [kN]	Tensile strength design value [kN]	L1 [mm]	L2 [mm]	L3 [mm]
R-M20	128.4	78.8	300	65	365

5.2.5 Setting up the energy storage system

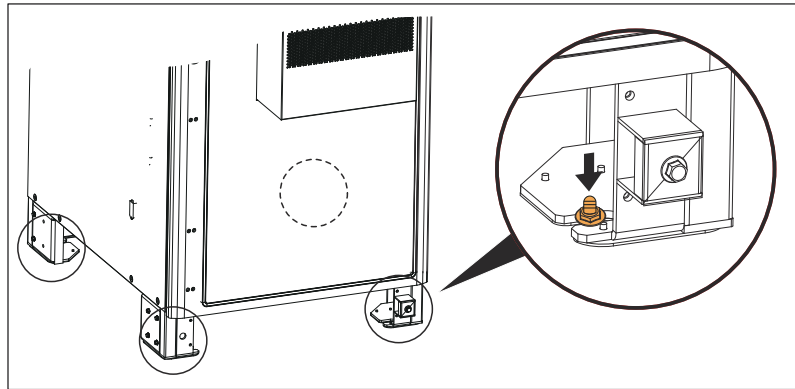

Fig. 21: Fixing the energy storage system in position

To fix the energy storage system in position, embed the M20 connection anchors in the foundation:

1. Use M20 nuts and washers.
2. Fix the energy storage system in position by inserting the connection anchors through the open extended holes in the feet.

If installing an additional cabinet extension, complete the following step before final positioning:

- ▶ Install the side base cover.



The remaining base cover is installed after the cabinet connectors have been connected.

5.3 Installing the battery inverter (wall mounting)



Mechanical installation

The energy storage system is delivered with the battery inverter pre-installed on the side and the cables already connected. For wall mounting, the battery inverter must first be removed.

Before removing it, ensure that the energy storage system is completely de-energised and secured against re-energisation.

The system-related requirements described here apply in addition to the manufacturer's instructions and take precedence in the event of discrepancies.

*Mechanical installation of the battery inverter is carried out in accordance with the manual for the **KACO blueplanet gridsave 92.0 TL3-S** from the manufacturer KACO new energy GmbH.*

5.3.1 Removing the battery inverter

Removing the DC cable

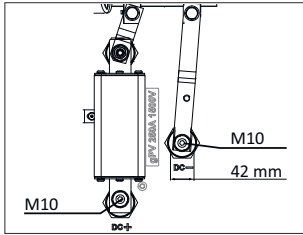

1. Release the casing cover by unscrewing the six screws and carefully remove it.
2. Loosen the cable gland on the battery inverter holder.
3. Place a size 16 ring/open-end spanner on the DC fuse holder and use it to loosen the hexagon nut.
4. Remove the ring cable lug and pull the DC cable downwards and out of the battery inverter.
5. Loosen the clamps with a Phillips screwdriver.
6. Pull the cables through the opening in the base plate.
7. Loosen the cable glands in the base of the cabinet.
8. To disconnect the DC cable [1], remove the nuts from the threaded studs and pull off the tubular cable lugs.
9. Pull the DC cable down through the cable glands and into the base.

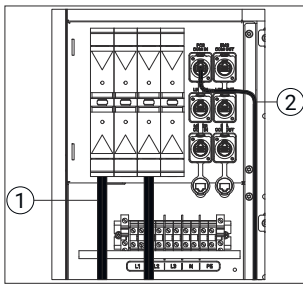

Removing the communication cable

1. Disconnect the RJ45 plug of the communication cable from the circuit board in the battery inverter.
2. Loosen the cable gland on the battery inverter and pull out the communication cable.
3. Remove the RJ45 plug from the energy management system jack inside the energy storage system cabinet.
4. Loosen the cable glands in the baseplate of the energy storage system and pull the cables downwards and out.
5. Loosen the U-clamps on the C-rail and remove the communication cable.

Removing the battery inverter

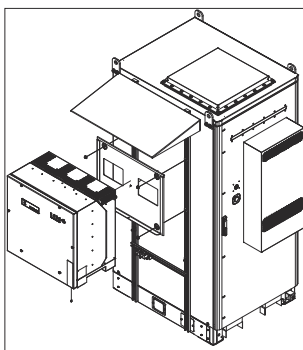

To enable wall installation of the battery inverter, detach the wall bracket from the energy storage system.

1. Place a size 13 spanner on the mounting rails of the energy storage system and use it to loosen the screws (T30/2 Nm) on the lower tabs of the holders.
2. Guide the battery inverter upwards over the suspension bracket and out of the holder.
3. Place a size 13 spanner on the mounting rails of the energy storage system and use it to loosen the four nuts securing the mounting plate.
4. Pull the holder off the threaded bolts.

5.3.2 Installing the battery inverter

- ▶ Install the battery inverter according to the manual for the **blueplanet grid-save 92.0 TL3-S**, document no. **MNL_BP_GS_92.0-137_TL3_0 5_en_us**, chapter **6 Assembly and preparation**.

6 Electrical connection

DANGER

Risk of electric shock from live cables or battery cabinet!

Live cables or a live voltage battery cabinet prior to installation can lead to electric shock, serious injury or death.

- Before commencing installation, make sure that all cables and the battery cabinet are de-energised.
- Use suitable measuring equipment to verify the absence of voltage.
- Do not carry out any work until this has been confirmed.

DANGER

Danger of death due to live batteries or electrical components!

Live batteries or electrical components can lead to life-threatening electric shocks, serious personal injuries, work-related accidents, overheating, cable breakage or short circuits. In addition, there is a risk of significant damage to the system.

- Before starting work, make sure that all batteries and electrical units are switched off and de-energised.
- Wear suitable personal protective equipment (a hard hat, gloves, safety goggles, insulating boots).
- After wiring and cabling, check that all cables have been laid correctly, are de-energised and are not subject to mechanical stress.
- Do not resume work until the safety check has been successfully completed.

DANGER

Risk of electric shock, fire and explosion due to incorrect DC connection!

A DC connection established incorrectly without authorisation or by unqualified personnel can result in electric shock, explosion, fire or system failure.

- Connections are only to be established by qualified specialist personnel.
- Establish all electrical connections in accordance with the applicable national standards and regulations.

DANGER

Risk of electric shock, fire and damage to equipment due to improper wiring!

Improper electrical connections by unqualified personnel or incorrect wiring due to failure to observe the markings can lead to electric shocks, short circuits, fire, damage to equipment, malfunctions or overheating.

- Electrical connections are only to be established by a qualified electrician or an appropriately qualified person.
- Strictly observe the wiring markings inside the unit.
- Do not resume work until a final check of the wiring has been carried out.

 **CAUTION****Risk of electric shock, short circuit and fire due to desiccants or damaged cables!**

Desiccants left inside the battery cabinet and damaged, poorly insulated or structurally defective cables can compromise electrical safety. This can lead to chemical reactions, overheating, short circuit, electric shock or fire.

- Before connecting the cables, remove all desiccants from the battery cabinet.
- Check all cables for proper insulation and mechanical integrity before carrying out wiring.
- Only use properly insulated cables that are intact.
- Remove and replace damaged or defective cables immediately.

 **CAUTION****Risk of short circuit, overheating and electric shock due to faulty wiring or mechanical stress on cables!**

Incorrect polarity, mechanical stress on the cable insulation, insufficient bend allowance, unsuitable screw lengths, pinched heat-shrink tubing, or faulty or loose wiring can lead to a short circuit, overheating, insulation damage, cable breakage, damage to equipment or electric shock.

- Check the polarity at both ends of the cable before connecting it.
- Do not pull the cable during wiring or install it under tension.
- Install cables with a sufficient bend radius and adequate bend allowance.
- If necessary, use suitable tools such as cable clamps.
- To prevent damage to the insulation, use screws of a suitable length.
- Ensure that the heat-shrink tubing is not pinched and retains its protective function.
- Check the wiring carefully after each work step.

 **CAUTION****Risk of fire and overheating due to faulty wiring or contact points!**

Incorrect wiring, following the incorrect connection sequence and loose or oxidised contact points can lead to a short circuit, local overheating or fire.

- Carry out wiring carefully and in the correct order according to the instructions.
- Tighten all connections and ensure clean, non-oxidised contact surfaces.

 **CAUTION****Risk of fire and short circuits due to faulty wiring or open cable entries!**

Faulty or loose wiring on completion of installation, as well as open cable entries that allow small animals to enter, can lead to a short circuit, overheating, cable damage or fire.

- After establishing all electrical connections, check the wiring carefully and make sure that all connections are correct and secure.
- After completing the check, seal all cable feedthroughs with fire-proof sealing material.

 **CAUTION****Risk of injury and damage to equipment due to climatic influences!**

There is a risk of the door slamming shut if it is opened in wind speeds of Beaufort force 6 or higher, or in rainy or wet conditions. This can cause injuries from falling parts and result in water entering the unit.

- Do not open the door if the wind speed is Beaufort force 6 or higher, or if it is raining or wet.

 **CAUTION****Risk of electric shock, fire or system failure due to improper cable installation!**

The improper installation of high-voltage, low-voltage and signal cables, open pipe ends or cable feedthroughs, and failure to comply with legal regulations and standards can lead to mechanical damage, electrical faults, short circuits, power failure, fire, system failure or electric shock.

- DC and AC cables should ideally be installed underground in metal conduits; ground the conduits at both ends.
- Route signal cables in grounded metal conduits or flexible metal conduits.
- Protect cable feedthroughs against sharp edges.
- Secure cables not installed in conduits with suitable holders and clamps, and route them close to the floor.
- Temporarily close the ends of the conduits during installation.
- After installation, seal all inlets, outlets and openings with fire-proof material.
- Select, install and route cables in accordance with local laws, regulations and applicable standards.

 **CAUTION****Risk of overheating and fire due to overloading of cables!**

Overloading the cable with excessive current can lead to overheating, cable fires, electrical damage, fire hazards and electric shock.

- Ensure that the current density does not exceed the limit of 3 A/mm².
- Use suitable cable cross-sections according to the actual current load.
- Carry out and verify cable dimensioning and installation in accordance with the technical specifications and applicable standards.

6.1 System examples

Energy services according to VDE-AR-N 4105

The following system diagram shows an example setup for battery storage systems that conform to VDE-AR-N 4105 and are connected to the low-voltage grid. The system is typically used for established energy services such as self-consumption optimisation, peak shaving, multi-use applications or direct marketing. The following are included in the standard scope of delivery: the TESVOLT FORTON energy storage system, the KACO battery inverter, an extension cabinet with cabinet connector set and a Janitza UMG 604 for measurements at the grid connection point (GCP). Other components shown are optional and depend on the structure of the overall system, for example additional generators, consumers or charging infrastructure. To enable system communication, a network switch must be installed in the customer station. In addition, certain projects may require the integration of network operator-specific control components. These include ripple control receivers, controls according to Section 14a of the German Energy Industry Act (EnWG) or telecontrol protocols such as IEC 60870-5-104. These components are not shown in the system diagram and must be individually factored in according to the requirements of the grid operator.

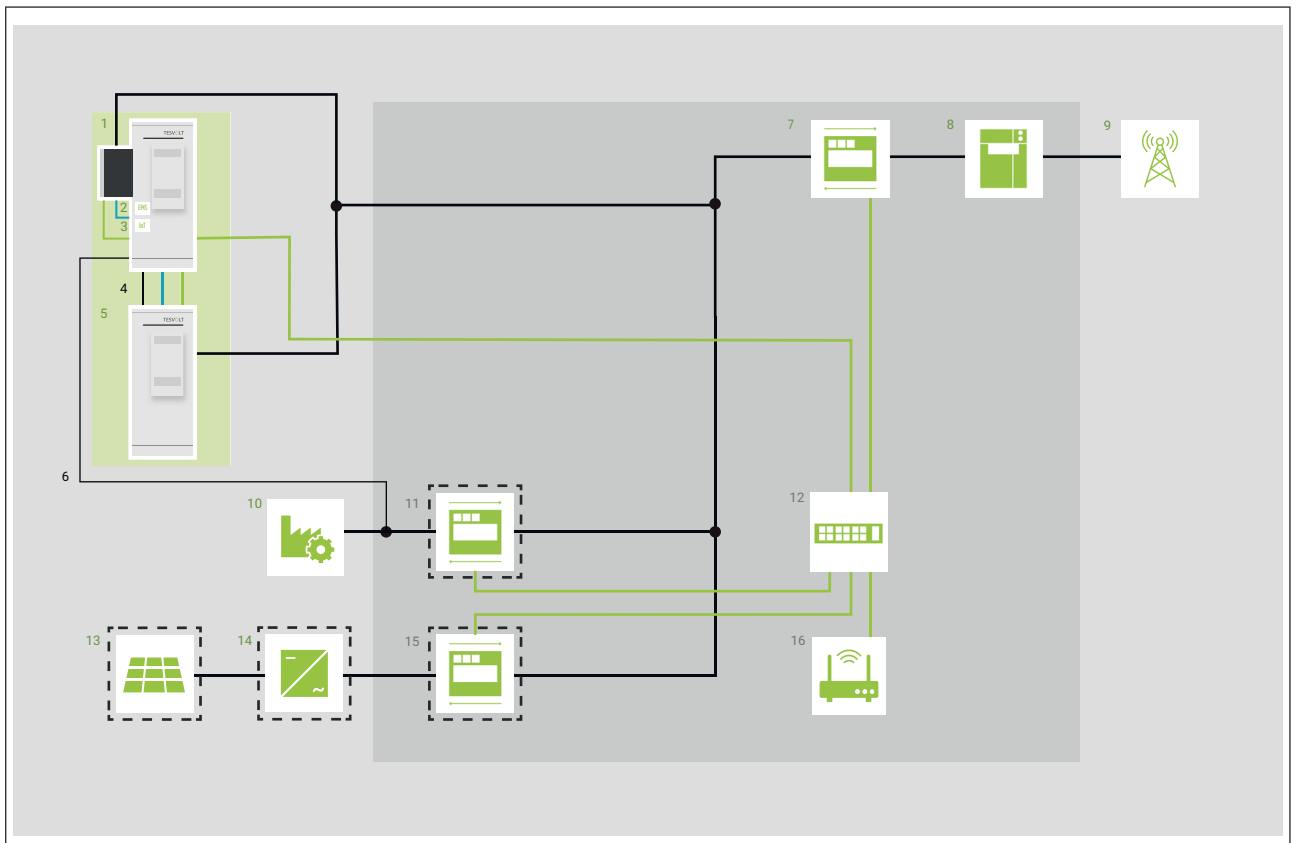

Fig. 22: Example system according to VDE-AR-N 4105

- | | |
|---------------------------------|---|
| — DC cable | [4] Cabinet connector set |
| — AC cable | [5] TESVOLT FORTON extension cabinet |
| — Communication cable | [6] TESVOLT FORTON AUX supply |
| --- Optional components | [7] Janitza UMG 604 power analyser at the grid connection point |
| --- Optional TESVOLT components | [8] GCP energy meter |
| — AUX | [9] Utility grid |
| ■ Customer distribution system | [10] Consumers |
| ■ TESVOLT scope of delivery | [11] Control meter (consumers) |
| [1] TESVOLT FORTON main cabinet | [12] Switch |
| [2] TESVOLT Energy Manager | [13] PV installation |
| [3] TESVOLT IoT gateway | [14] PV inverters |

- | | |
|---|---|
| [3] TESVOLT IoT gateway | [12] Consumers |
| [4] Cabinet connector set | [13] Control meter (consumers) |
| [5] TESVOLT FORTON extension cabinet | [14] Switch |
| [6] TESVOLT FORTON AUX supply | [15] Farm controller (master EZA controller) |
| [7] Janitza UMG 604 power analyser | [16] PV installation |
| [8] Janitza UMG 604 power analyser at the grid connection point | [17] PV inverters |
| [9] GCP energy meter | [18] Control meter (PV installation) |
| [10] Utility grid | [19] Customer router |
| [11] TESVOLT ENERGY Controller Pro S (TEC Pro S) | [20] Distribution system operator gateway (DSO gateway) |

6.2 Overview of cable entries

The battery inverter is already connected to the energy storage system on delivery. The cables run through the cable entry in the base of the energy storage system. When combining several energy storage systems, you must connect them to the cables of the cabinet connector set via the cable entries.

Arrangement on delivery

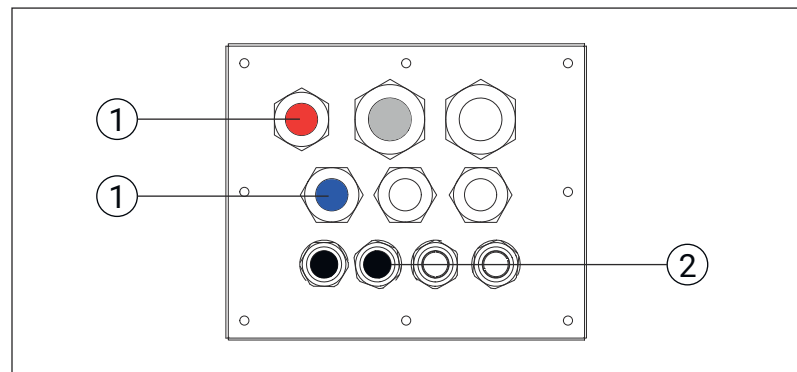

Fig. 24: Cable entry on delivery

- [1] Battery inverter DC cables (red/blue)
 [2] Communication cable running to battery inverter (black)

System-to-system arrangement

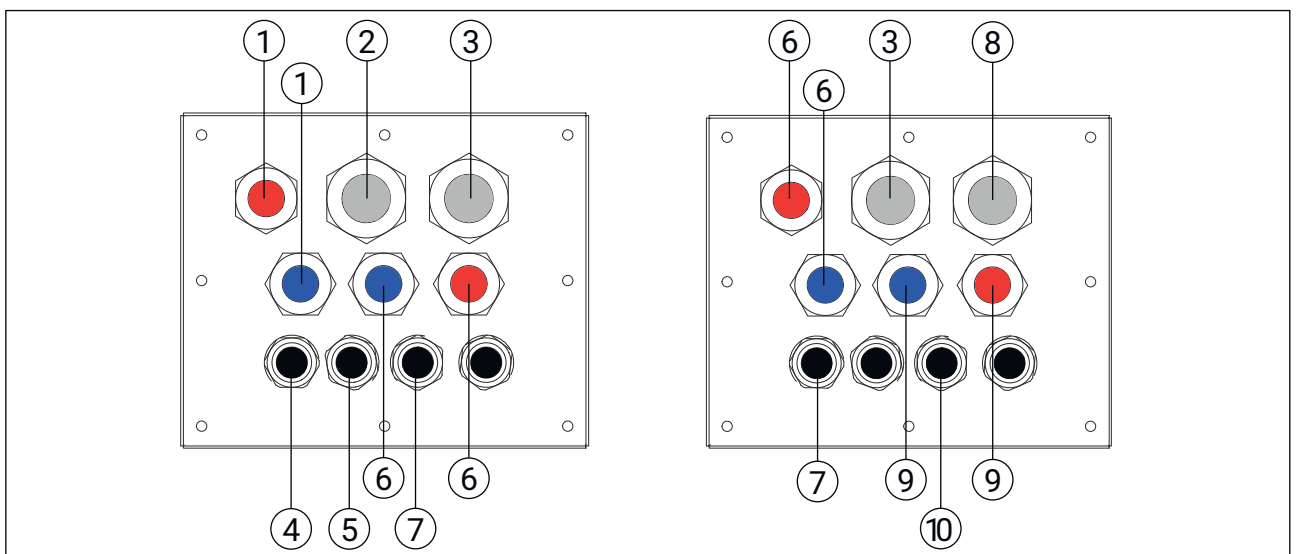

Fig. 25: System-to-system cable entry

- [1] Battery inverter DC cable [2] AUX

[3] AUX LINK 1	[7] COM LINK 1
[4] COM battery inverter	[8] AUX LINK 2
[5] COM EZA/EMS/meter	[9] LINK 2 DC cable
[6] LINK 1 DC cable	[10] COM LINK 2

6.3 Installing the grounding

WARNING

Danger of death if the energy storage system cabinet is not sufficiently grounded!

Insufficient grounding of the energy storage system cabinet can result in a life-threatening electric shock in the event of a fault. In addition, damage to the energy storage system cabinet and battery system malfunctions may occur.

- Ensure the grounding resistance is $< 10 \Omega$.
- Check the grounding connection carefully and make sure that the grounding cable is correctly connected at both ends.
- Carry out regular measurements and maintenance in accordance with the applicable standards and regulations.

CAUTION

Risk of fire and system failure due to lack of lightning protection!

A lack of protection against direct lightning strikes can result in damage to the energy storage system cabinet, failure of the energy storage system and an increased risk of fire and safety hazards.

- Install suitable lightning protection measures (e.g. an external lightning protection system, grounding system) in accordance with the applicable standards and regulations.
- Take lightning protection into account as early as the planning and installation phases.

CAUTION

Safety and conformity risks due to non-standard cable colours!

Cable colours that do not comply with local regulations can lead to confusion during installation and maintenance, safety risks due to conductor mix-ups and non-compliance with local standards and regulations.

- Only use cable colours in accordance with applicable local cable standards and regulations.
- The cable colours referred to in this document are for guidance only and are not binding.

A grounding cable (green-yellow) with a cross-section of $\geq 25 \text{ mm}^2$ is required to ground the energy storage system.

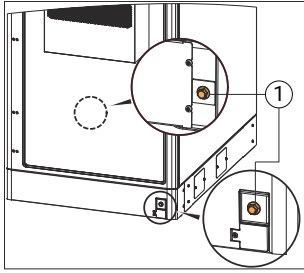

- ▶ Attach the grounding cable to the grounding point [1] using an M10 x 25 mm flanged hex bolt and a tightening torque of 30 Nm.

6.4 Installing the weather canopy

The weather canopy for the battery inverter is included with the energy storage system. It must be installed before commissioning.

Proceed as follows to open the door of the energy storage system:

- ▶ Remove the key from the heat exchanger and use it to unlock the door.

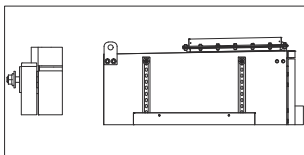

- 1.** ▶ Loosen the self-locking nut and the first washer from the two upper threaded bolts.

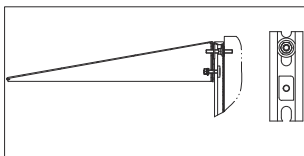

- 2.** ▶ Slide the weather canopy through the upper holes onto the thread bolts, while inserting the hammer-head screws vertically into the C-rail.

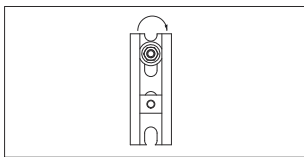

- 3.** ▶ Turn the hammer-head screws 90 degrees.

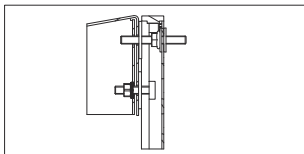

- 4.** ▶ Tighten the self-locking nut and washer on each hammer-head screw.

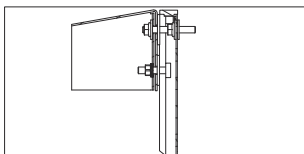

- 5.** ▶ Fasten the self-locking nut and washer on the two upper threaded bolts.

6.5 Installing the side base cover

The base cover on the left-hand side of the main cabinet is pre-installed. The unit is delivered with the remaining base covers attached to the inside of the cabinet door.

Main cabinet

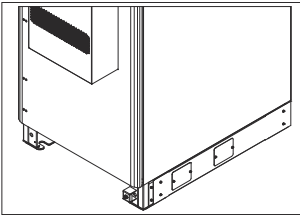

- ▶ Install the base cover on the right-hand side of the energy storage system.

Main cabinet with extension cabinet

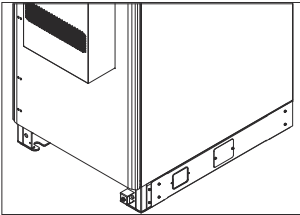

Before final installation of the extension cabinet:

- 1.** ▶ To install the connecting cables later, remove the panel from the front opening of the right-hand base cover.
- 2.** ▶ Install the base cover on the right-hand side of the energy storage system.
- 3.** ▶ Install suitable edge guards on all openings from which panels have been removed.

Extension cabinet

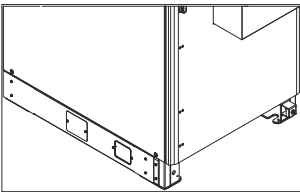

- 1.** ▶ Remove the panel from the front opening of the left-hand base cover.
- 2.** ▶ If installing another extension cabinet, remove the panel from the front opening of the right-hand base cover.
- 3.** ▶ Install suitable edge guards on all openings from which panels have been removed.

6.6 Connecting the module connectors

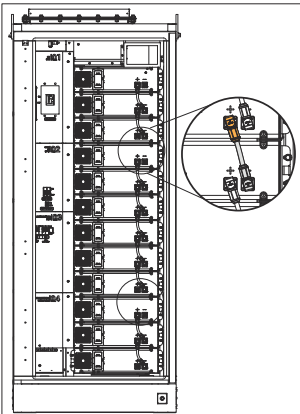

- 1.** ▶ Using the first module connector, connect the positive pole on module 3 to the negative pole on module 4.
- 2.** ▶ Use the second module connector to connect the positive pole on module 9 to the negative pole on module 10.

6.7 Connecting the HV unit

For safety reasons, the first and last battery modules are not connected to the HV unit on delivery. The energy storage system comes with the cables pre-installed and these must be connected before commissioning.

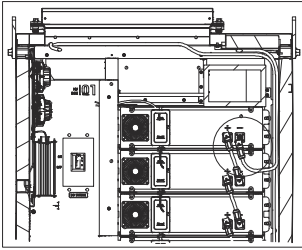

1. → Connect the top battery module to the HV unit.

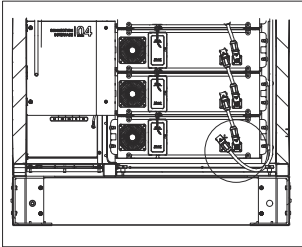

2. → Connect the bottom battery module to the HV unit.

6.8 Removing the cable cover

To remove the cable cover:

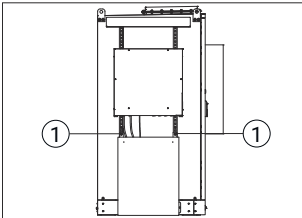

1. → Unscrew the top M8 screwed connection [1] with a size 13 spanner.

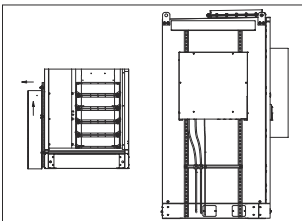

2. → Pull the cable cover upwards and then away from the energy storage system.

6.9 Installing cables

Before installation:

- ▶ Check all cables for possible transport damage.

Proceed as follows to install the cables:

- ▶ Remove the cover 04.

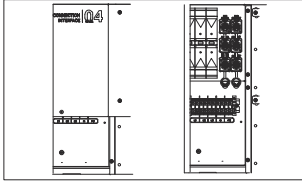

6.9.1 Installing the communication cables

Internet connection requirements

The system requires an Internet connection with a speed of **at least 50 Mbit/s**. So as not to impede remote services, there must be **no limitation on data** when using a local LTE router.

The communication cable from the battery inverter to the '*PCS COM IN*' communication input is pre-installed.

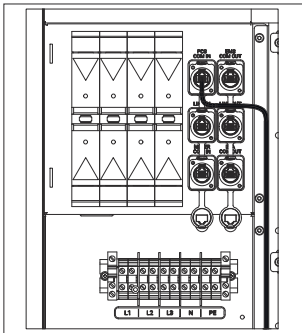

1. ▶ Optional: Connect the communication cable to the external *METER COM IN* meter communication input.

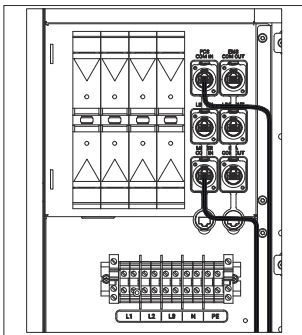

2. ▶ Connect the communication cable to the *EMS COM OUT* EMS communication output.

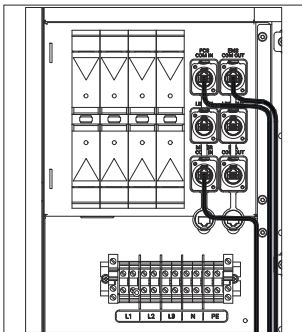

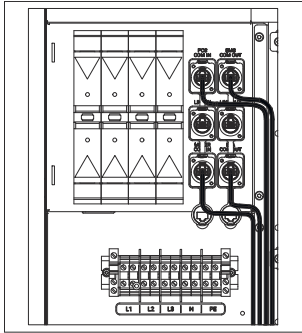

3. → Optional: Connect the communication cable at the EMS communication output to work in conjunction with the *EZA COM OUT* EZA controller.

6.9.2 Connecting two energy storage systems

To connect two or more energy storage systems, you must use the cable gland in the base plate of the energy storage system and the opening in the base cover plates.

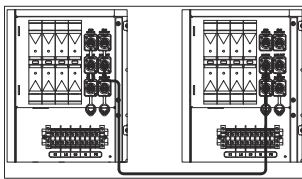

- ▶ Take the communication cable from the cabinet connector set, then connect it between the *LINK OUT* BMS communication connection of the main cabinet and the *LINK IN* BMS communication connection of the extension cabinet.

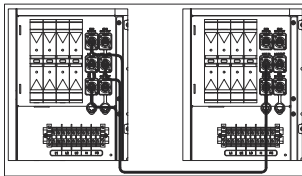

- ▶ Connect the communication cable to the *METER COM IN* external meter communication input.

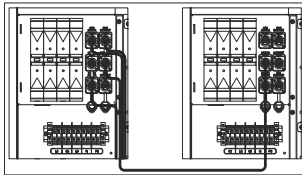

- ▶ Connect the communication cable to the *EMS COM OUT* EMS communication output.

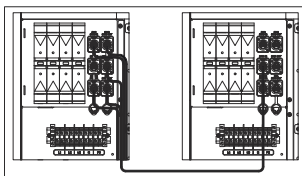

- ▶ Connect the communication cable at the EMS communication output to work in conjunction with the *EZA COM OUT* EZA controller.

The following safeguards must be observed for the *LINK IN* and *LINK OUT* BMS communication connections:

1. → To connect the communication cable to the next energy storage system, remove the *terminal resistor* at the *LINK IN* BMS communication connection of the main cabinet.
2. → To connect the communication cable to the last energy storage system, remove the *terminal resistor* at the *LINK OUT* BMS communication connection of the last energy storage system.

6.9.3 Installing the DC connecting cables

The DC connecting cables running to the battery inverter are pre-installed.

To connect the DC connecting cables from the main cabinet to the next energy storage system:

1. → Loosen the M8 nuts.

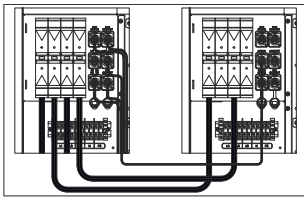

2. → Secure the positive (+) cable end to the DC+ fuse holder (main cabinet) according to the battery polarity, using a tightening torque of 12 Nm.
3. → Secure the positive (+) cable end to the DC+ fuse holder (extension cabinet) according to the battery polarity, using a tightening torque of 12 Nm.
4. → Secure the negative (-) cable end to the DC- fuse holder (main cabinet) according to the battery polarity, using a tightening torque of 12 Nm.
5. → Secure the negative (-) cable end to the DC- fuse holder (cabinet 2) according to the battery polarity.
6. → Secure the covers 04 of the connections.

6.10 Connecting the external fire alarm system

Connection

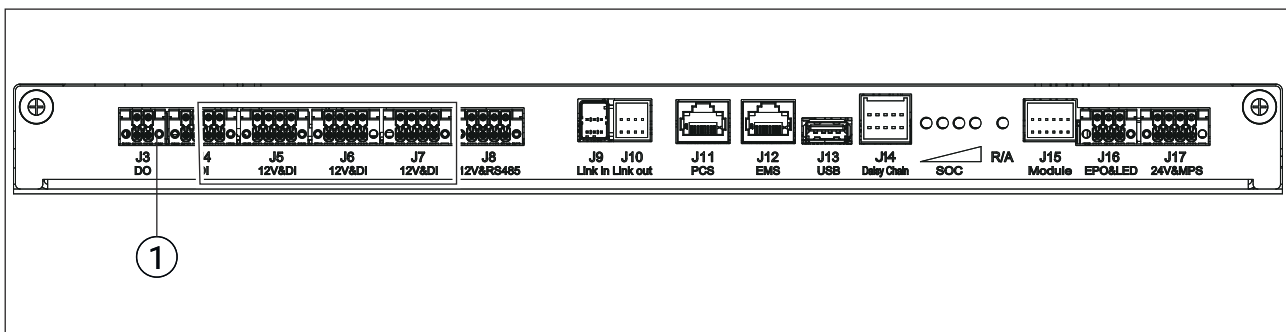

Fig. 26: Fire alarm system connection

A fire alarm system can be optionally integrated into the energy storage system using connection [1] J3 DO of the HV unit.

Pin assignment

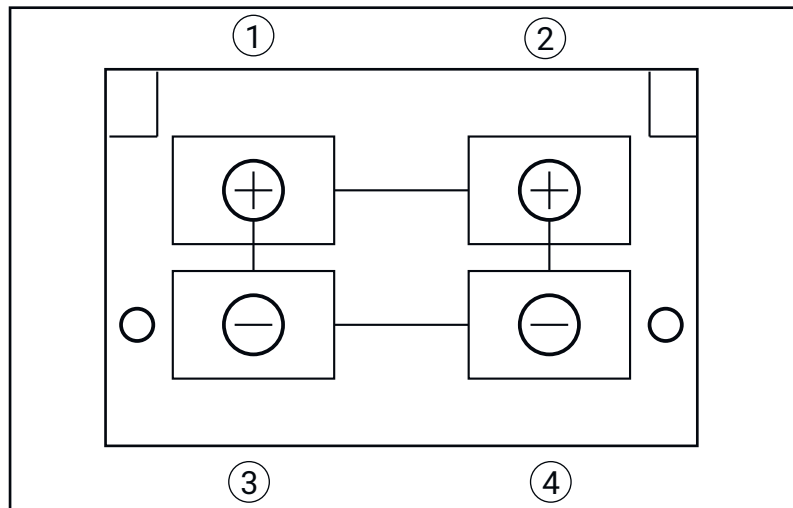

Fig. 27: Pin assignment of the fire alarm system

Tab. 2: Key

No.	Designation	Description
[1]	DO 1+	Output for fire alarm system signal
[2]	DO 2+	Output signal for DC relay dropped out
[3]	DO 1-	Output for fire alarm system signal

No.	Designation	Description
[4]	DO 2-	Output signal for DC relay dropped out

6.11 Installing the aerosol fire extinguishing system

To ensure safety during transport, the aerosol fire extinguishing system is not fully installed. Two cables must be connected to make the system ready for operation.

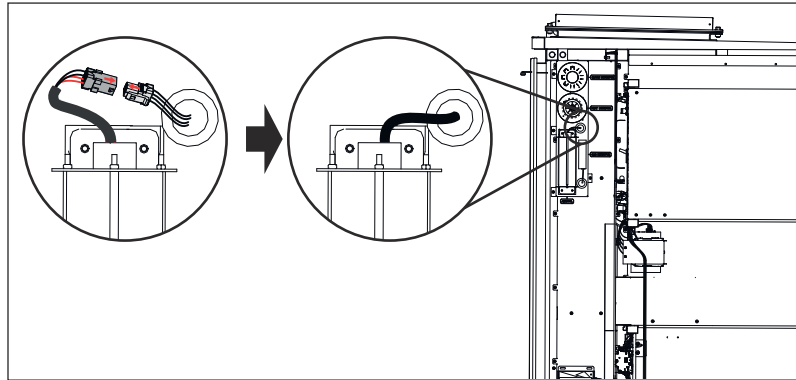

- ▶ Connect the two plugs to each other on the aerosol extinguishing generator.

6.12 AC connection of the KACO blueplanet 92kW TL3

CAUTION

Material damage due to gases that aggressively attack surfaces in humid weather conditions!

The unit casing can be severely damaged by gases (e.g. ammonia, sulphur) in humid weather conditions.

- If the unit is exposed to gases, it must be installed in a visible location.
- Regularly carry out visual inspections.
- Remove any moisture from the casing immediately.
- Ensure sufficient ventilation at the installation site.
- Remove any dirt – especially on the ventilation components – immediately.
- Failure to comply with this safety instruction will invalidate the guarantee in the case of damage to the unit.

Requirements for supply lines

DC side	
Max. cable cross-section	240 mm ² (AL or CU)
Min. cable cross-section	In accordance with local installation standards
Cable diameter for cable gland	16...28 mm
Cable lug dimension b – maximum width	42 mm

Stripping length	Varies according to the cable lug
Recommended cable type	Solar cable
Cable lug connection bolt Ø	Drill hole for M10 screw
Tightening torque	30 Nm
Cable gland for DC connection	M40
Torque for cable gland	10 Nm
AC side	
Max. cable cross-section	240 mm ² (AL or CU)
Min. cable cross-section	In accordance with local installation standards
Cable diameter for cable gland	16...28 mm
Stripping length	Varies according to the cable lug
Cable lug connection bolt Ø	Drill hole for M10 screw
Tightening torque	10 Nm
Connection type	Cable lug (use a cable lug suitable for the cable material)
Cable lug dimension b – maximum width	42 mm
Protective conductor connection	M10
Tightening torque of the protective conductor connection	10 Nm
Fuse protection to be provided by the customer during installation (max. overcurrent protection output)	Max. 250 A
Cable gland for AC connection	M40
Torque for cable gland	10 Nm

Removing the casing cover

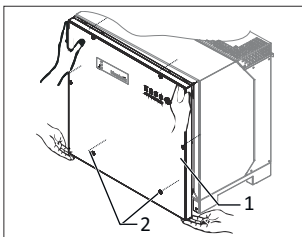

1. Release the casing cover [1] by unscrewing the six screws [2] and carefully remove it.
2. When setting down the casing cover, take care not to damage the seals and optical fibres or to get them dirty.

Overview of the connection area

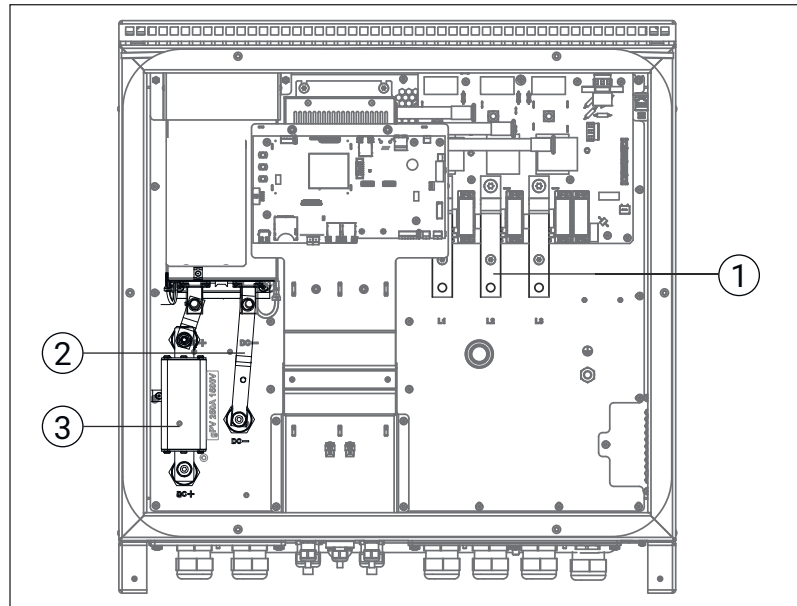

Fig. 28: Overview of the KACO AC connections

- [1] AC connecting terminal
- [2] DC connection point
- [3] DC fuse with connecting terminal

6.12.1 Connecting the battery inverter to the utility grid

CAUTION

Fire hazard due to chemical corrosion!

- Use cable lugs that are suitable for the conductor material and copper busbars.



Suitable cable lugs

When using aluminium cable lugs, we recommend the use of tin-plated cable lugs or, alternatively, AL/CU cable lugs along with matching AL/CU washers. Otherwise, if electrolytes are present (e.g. condensation), the aluminium may be destroyed by the copper busbar.



Metal fittings

When using metal fittings, toothed washers must be placed underneath to ground the casing.

Preparing the grid connection



In addition to the supplied connection plate, a connection plate with M63/32 cable glands is available for order.

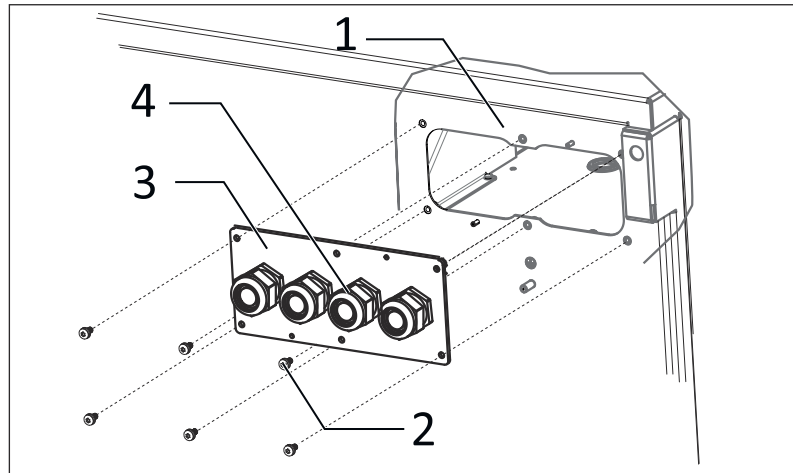

Fig. 29: Grid connection

- [1] Bottom of the casing – AC side
- [2] Screws for fastening
- [3] Input plate
- [4] Cable gland

- 1.** Loosen the cable gland for the AC connection and PE (ground).
- 2.** Remove the sealing insert.
- 3.** Insert the AC cables through the cable glands.
- 4.** Strip the AC cables.
- 5.** Strip the individual wires for L1/L2/L3 and PE so that the strands and insulation can be pressed into the shaft of the cable lug.
- 6.** Press on the cable lug.
- 7.** Pull a heat-shrink tube (not included in the scope of delivery) over the shaft of the ring cable lug of the AC cable.
- 8.** Secure the input plate by tightening the six screws to a torque of 6 Nm.

Establishing the grid connection

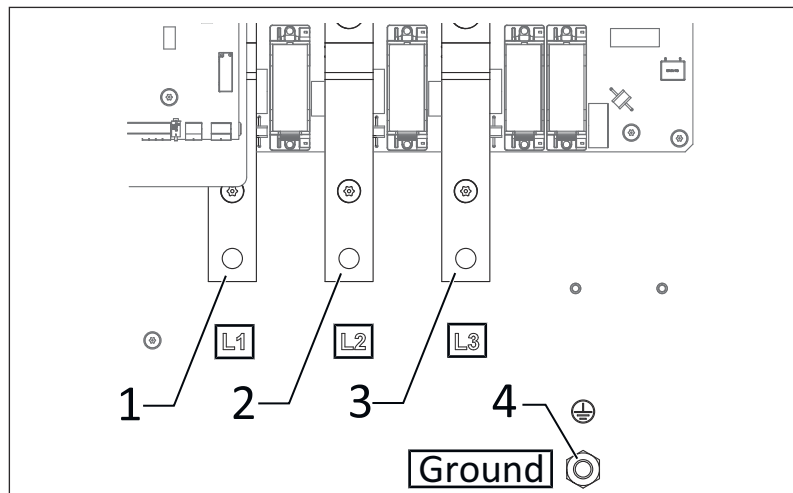

Fig. 30: Grid connection

- [1] L1 busbar
- [2] L2 busbar
- [3] L3 busbar
- [4] Ground – grounding point

1. ➤ Loosen the nut with lock washer at the designated grounding point.
2. ➤ Place the grounding cable on the grounding point. Secure it with the designated nut and lock washer and tighten to a torque of 10 Nm.
3. ➤ Place the cable lugs of the L1/L2/L3 wires on the busbar according to the markings and secure them with a screw, nut and lock washer, and tighten to a torque of 30 Nm.
4. ➤ Check that all connected cables are secure.
5. ➤ Tighten the AC cable glands to a torque of 10 Nm.
 - ➔ The battery inverter is connected to the power grid.

6.13 Installing the AC auxiliary power cable

CAUTION

Risk of malfunction and overloading of the auxiliary power supply when using parallel battery cabinets!

An imbalance or overload of the auxiliary power supply when using parallel battery cabinets can lead to malfunctions in the auxiliary power supply and overloading of individual phases. This can cause outages or damage to the system.

- If the single-phase auxiliary power supply is insufficient, connect the auxiliary power supply to the utility grid (L1/L2/L3/N/PE, 380 V AC).
- Use the recommended wiring method to avoid a three-phase imbalance.
- Note: In the factory configuration, power is drawn from XT1 (L1/N), so change the connection from XT1 to L2 or L3 if necessary.

Requirements for fuse protection



Cables must be selected and the components installed in conformity with local regulations (e.g. DIN VDE 0100). The work must be carried out by a qualified electrician.

Tab. 3: Configuration: 1 main cabinet

Max. operating current	Cable	Requirements
12 A	3-core	<ul style="list-style-type: none"> ■ Taking into account the cable installation method, a supply cable rated for at least 12 A continuous current must be selected. ■ The supply cable must be protected by a line circuit breaker.

Tab. 4: Configuration: 1 main cabinet, up to 2 extension cabinets

Max. operating current per phase	Cable	Requirements
12 A	5-core	<ul style="list-style-type: none"> ■ Taking into account the cable installation method, a supply cable rated for at least 12 A continuous current must be selected. ■ The supply cable must be protected by a circuit breaker rated for a current of max.25 A.

Tab. 5: Configuration: 1 main cabinet, 3 extension cabinets (maximum configuration)

Max. operating current per phase	Cable	Requirements
24 A (a double-loaded phase)	5-core	<ul style="list-style-type: none"> ■ Taking into account the cable installation method, a supply cable rated for at least 25 A continuous current must be selected. ■ The supply cable must be protected by a circuit breaker rated for a current of max.25 A.

Main cabinet

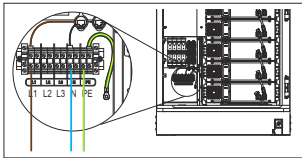

- ▶ Connect the AC auxiliary power cable from the AC power source (L/N/PE) to the energy storage system (L1/L2/L3/N/PE) using a tightening torque of 1.5...1.8 Nm.

Extension cabinets

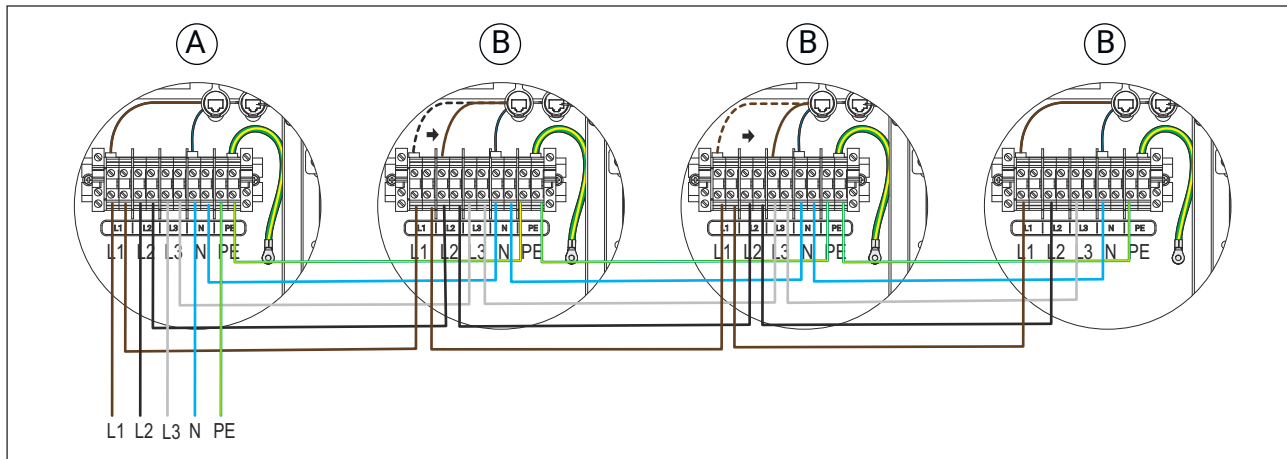

- [A] Main cabinet
[B] Extension cabinet

1. ▶ Connect the AC auxiliary power cable of the main cabinet from the AC power source to the extension cabinet (L1/L2/L3/N/PE) using a tightening torque of 1.5...1.8 Nm.
2. ▶ Connect the extension energy storage systems to each other using the AC AUX cable from the cabinet connector set.

3. ▶ Reconnect the internal AC auxiliary power connecting cable to the top outgoing connection point of the first terminal for the extension cabinets [B], as shown in the diagram. For the first extension cabinet, reconnect from L1 to L2 and for the second extension cabinet, from L1 to L3. The third extension cabinet does not need to be reconnected to a different phase.

6.14 Installing the cable cover

To install the cable cover:

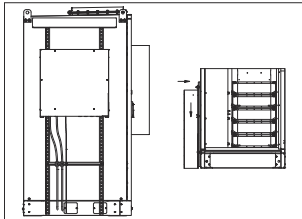

1. ▶ Place the cable cover over the cables and lower it until it clicks into place.

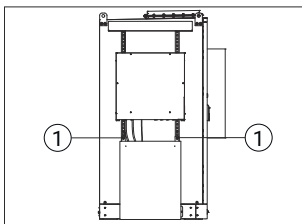

2. ▶ Fasten the top M8 screwed connection [1] with a size 13 spanner.

6.15 Janitza UMG 604-Pro power analyser

The power analyser is used to measure energy flows at the point within the system where control is exerted. In most cases, the control point is located at the grid connection point.



Surge protection

To protect units from transient voltages and grid disturbances, we recommend using a surge protection module (e.g. RS485 protection modules) whenever communication lines exceed a length of 10 m.

Installation notes

- Install the power analyser in a control cabinet or small installation distributor board on a 35 mm mounting rail in any installation position.
- Do not run the communication cables parallel to high-voltage cables.
- Observe a minimum distance of 20 cm from power cables.
- At crossings, lay cables at right angles.

6.16 Installing the base cover

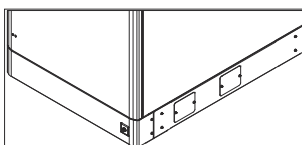

- ▶ Install the base covers on the front and rear of the energy storage system.

7 Commissioning

WARNING

Danger of death due to electric shock!

At cold temperatures, condensation can form on the electronics. This condensation can affect the properties of insulation materials, thereby creating an electrical hazard.

Commissioning the system in rain, snow or fog may create an electrical hazard.

- Do **not** commission the system at low temperatures or in snow, rain, thunderstorms or fog.

CAUTION

Personal injury and material damage due to failure to observe the safety rules!

There is a risk of personal injury and material damage if the five safety rules are disregarded when working on live parts of the energy storage system.

- Disconnect from the mains.
- Secure against re-energisation.
- Determine the absence of voltage.
- Ground and short circuit.
- Cover or shield adjacent live parts.



The system is commissioned by switching on and configuring the individual elements. The list below provides an overview of all the steps required for successful commissioning.

Commissioning

- Check the system.
- Configure the Janitza UMG 604-Pro power analyser.
- Switch on the KACO battery inverter.
- Switch on the energy storage system.
- Switch on the EZA controller. (Optional)
- Configure the KACO battery inverter.
- Configure the IoT gateway.
- Set up the TESVOLT Energy Manager.
- Set up the TESVOLT Energy EZA Pro. (Optional)
- Configure the system in the TESVOLT Cloud.
- Conduct a functional test of TESVOLT Energy.

7.1 Testing the system

Checking the cable connections

- 1.**  Check whether any cables are damaged or torn.
- 2.**  Ensure that all cables are connected correctly according to the wiring diagram.
- 3.**  Check that all cable connections are firmly secured.

4. → Check the connections of the DC cables and retighten them if necessary.



Battery inverter tightening torque: 30 Nm/energy storage system tightening torque: 12 Nm

5. → Check that the grounding point in the control cabinet is connected to the grounding point of the foundation.

Checking the high-voltage unit

Before checking the battery modules:

- ▶ Turn off the DC circuit breaker on the high-voltage unit.

Checking the battery voltage

1. → Measure and document the no-load voltage of each battery module.



The battery module voltage at 30% SOC is 72.96 V_{DC}.

2. → Ensure that the DC cables coming from the battery inverter are correctly connected to the battery module.
3. → Measure the battery voltage with a multimeter.



When switched off, the battery voltage on the high-voltage unit must be 0 V.

Testing the system

The test is based on DIN VDE 0100-600.

1. → Measure the grounding resistance or the continuity of the PE conductor.
2. → Measure the insulation resistance.
3. → Note down the measured values and enter them in the digital commissioning report during system configuration.

7.2 Configuring the Janitza power analyser

Advanced IP scanner



The IP address of the power analyser is assigned arbitrarily by the DHCP server.

To set a fixed IP address:

- *Set the IP address using the GridVis software.*

To establish a connection to the power analyser, the first step is to retrieve the device's IP address:

1. → Connect your laptop to the local network.
2. → Open the *Advanced IP Scanner* software.

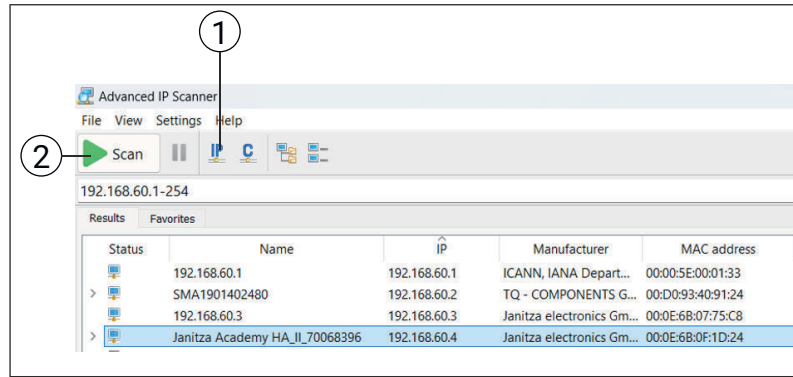

3. Click on the **[IP]** button [1] and select the IP address range.
4. Click on the **[Scan]** button [2].
 - ➔ The software scans the stations on the network and the relevant devices are displayed.

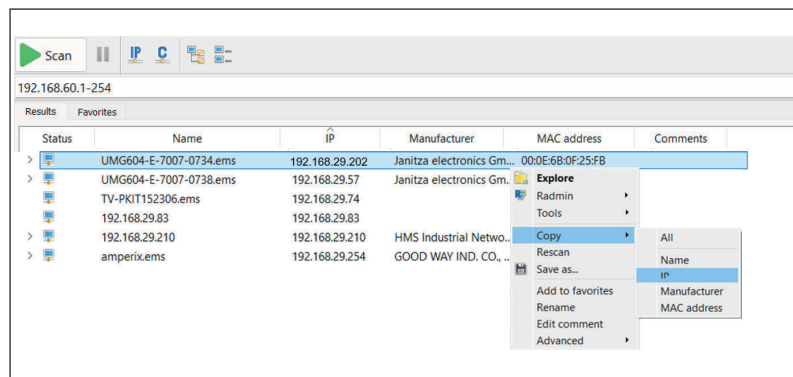

5. Right-click on the power analyser and select **'Copy → IP'**.
 - ➔ The power analyser's IP address is now on the clipboard.

Accessing the Janitza web interface

- Paste the previously copied IP address into a web browser and access it.
- ➔ The Janitza web interface opens.

7.2.1 Adding the power analyser in GridVis

Changing the licence

The GridVis software can be downloaded free of charge from the Janitza website. To add the power analyser, you first need to change your license to the free GridVis BASIC version:

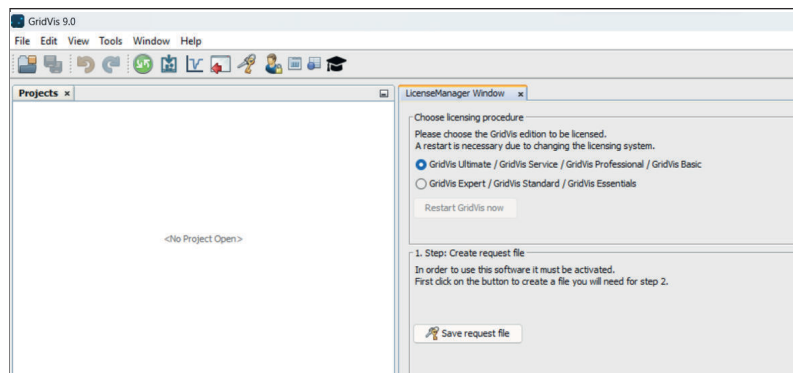

1. Open the *GridVis* software.
2. Open the *LicenseManager Window*.

3. Select the free version of the software (GridVis Basic).

Creating a new project

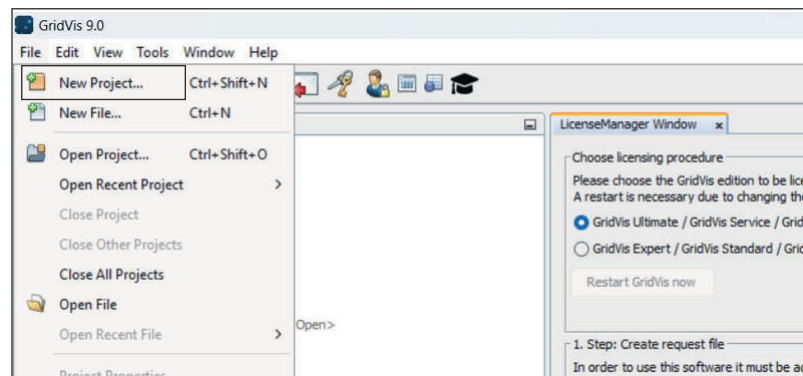

1. Click on the 'File → New Project' tabs.
 - ➔ A new window opens.
2. Click on 'Next'.
 - ➔ The project path window opens.

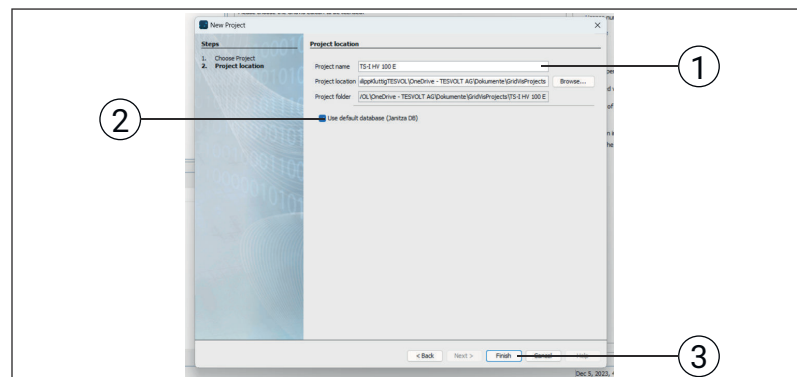

3. Enter a unique project name in the *Project name* field [1].
4. If you would like to save the project to your own database, remove the check mark [2].
5. Click on [*Finish*] [3] to confirm the project path.
 - ➔ The project is displayed in the *Projects* window.

Adding the power analyser to the project

1. In the *Projects* window, click on the plus icon (+) next to the project name.

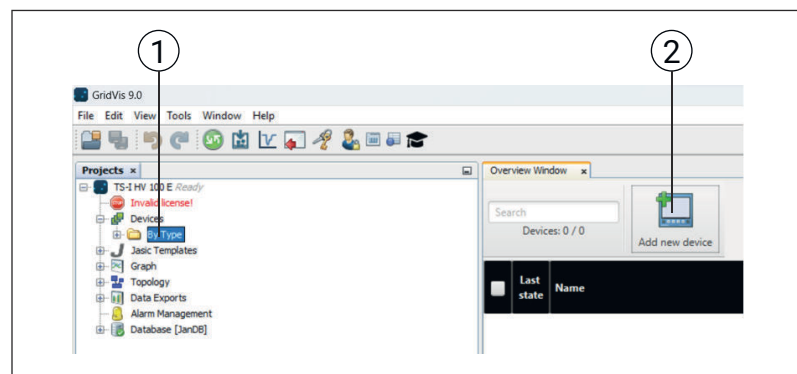

2. Select 'Devices → By Type' [1].

3. In the Overview window, click on **[Add new device]** [2].
 ➔ The **Choose File Type** window opens.

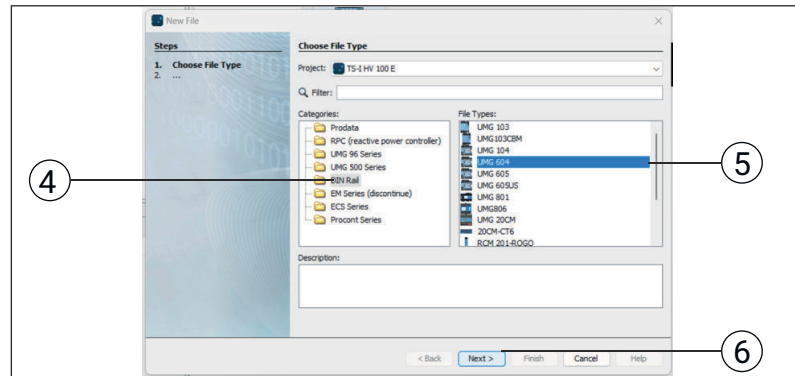

4. Select **'Categories → DIN Rail'** [4].
5. Select **'File Types → UMG 604'** [5].
6. Click on **[Next]** [6] to confirm your selection.
 ➔ The **Configure Connection** window opens.
7. Select **'TYPE → TCP/IP'**.
8. Click on **[Finish]** to confirm your selection.

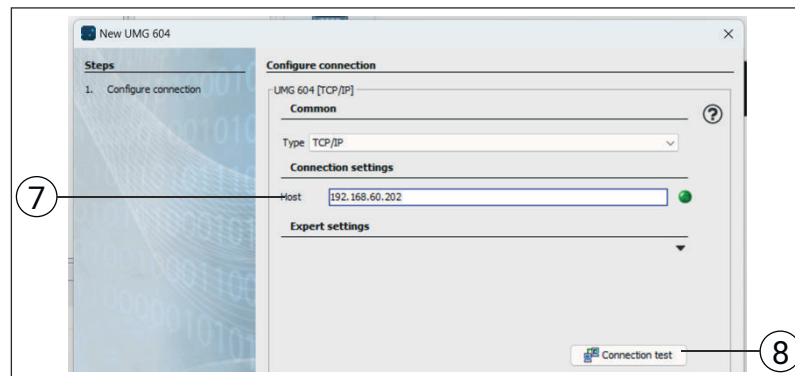

9. Paste the power analyser's IP address under **'Communication settings → Host/IP address'** [7].
10. Click on **[Connection test]** [8].
 ➔ The connection test is performed.
11. On successful completion of the connection test, confirm with **[OK]**.
12. Click on **[Finish]** to complete the connection configuration process.

Configuring the power analyser

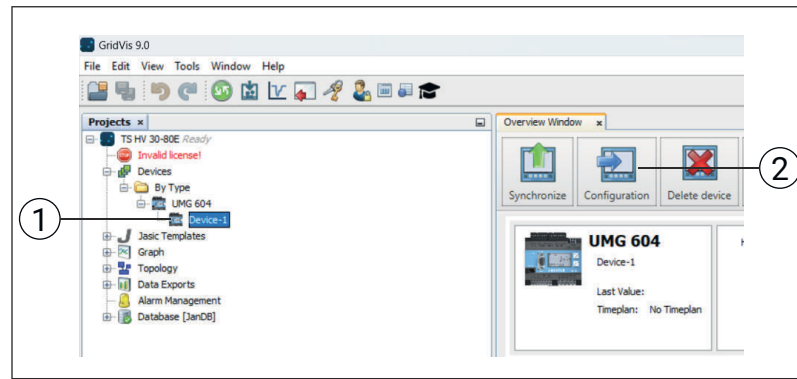

1. In the *Projects* window, select the Janitza *UMG 604* power analyser [1].
2. Click on *[Configuration]* [2].
3. The *Configuration* window opens.
4. On the *Identity* tab, enter the name and a description of the power analyser.
5. On the *Transformer* tab, configure the transformer ratios according to the installation manual.
6. If a mistake has been made during wiring, swap the phases and/or the measuring direction of the phases virtually on the *Phase mapping* tab.
7. On the *IP configuration* tab, assign the fixed IP address provided by the IT administrator.



Only assign the DNS server if it has been set by the company's IT administrator.

8. Click on *[Transmit]*.
9. The power analyser has been configured.

7.2.2 Checking the configuration

To complete the configuration, it must be checked in the Janitza web interface:

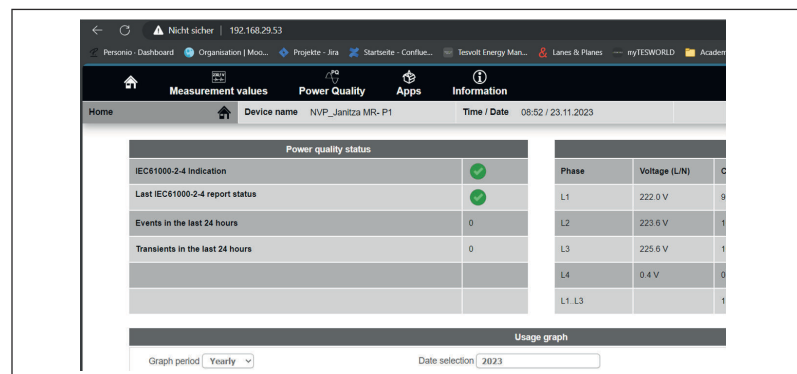

1. Open the Janitza web interface. ➔ *'Accessing the Janitza web interface' on page 76*
2. Check the new IP and phase configuration.

7.3 Switching on the KACO battery inverter

Proceed as follows to supply the battery inverter with mains voltage:

- ▶ Close the AC contactor or the AC back-up fuse on the main distribution board.
- ➔ The battery inverter starts up.

7.4 Commissioning the energy storage system

Proceed as follows to switch on the energy storage system:

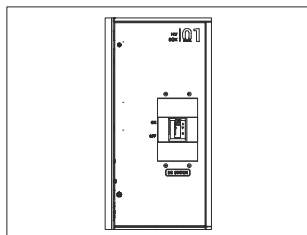

1. ➔ Set the DC SWITCH on the high-voltage unit to **[ON]**.

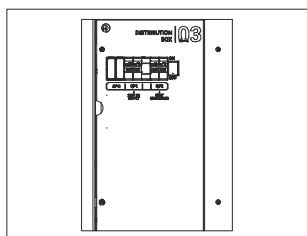

2. ➔ Close fuse QF1 (AC auxiliary power supply) on COVER 03.
3. ➔ Close fuse QF2 (heat exchanger switch) on COVER 03.

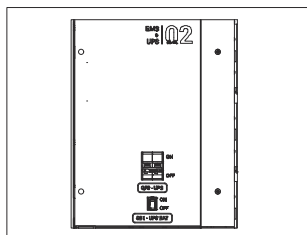

4. ➔ Close fuse QF3 (uninterruptible power supply, TESVOLT Energy Manager and TESVOLT IoT gateway) on COVER 02.
5. ➔ Close fuse QF4 (lead-acid battery connector switch) on COVER 02.

7.5 Commissioning the KACO battery inverter

To commission the battery inverter, the web interface must be opened and certain settings made.

To establish a connection to the battery inverter:

1. ➔ Open a web browser.
2. ➔ Access the KACO inverter UI using the URL `http://gb92-92-0TL<SN#>`.



If the battery inverter is not displayed with this method:

- Use the IP scan tool to search for the battery inverter.
- Access the battery inverter using its static IP.
- Follow the manufacturer's instructions.

3. ➔ Log onto the page by entering **user** as the user name and **kaco-user** as the password.
4. ➔ Open the installation wizard via the '**Configuration**' main menu.



If you need to make any changes to the configured parameters (e.g. factory settings, certificate change) at a later date, please contact TESVOLT Service. Separate login credentials are required to make these adjustments.

Language selection



The installation wizard has been started or restarted.

1. Click on **'Overview → Language'** to select the menu language from the drop-down menu.
2. Confirm your selection to proceed.
 - ➔ The **[Next]** button takes you to the next installation step.

Country configuration

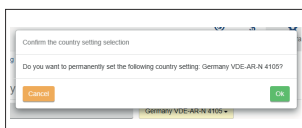
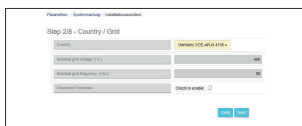

NOTE: This option controls the country-specific operating settings for the device. For more information, please contact KACO Service.

1. Use **'AC settings → Country and grid type'** to select the country and grid type.
2. Confirm your selection to proceed.
 - ➔ The **[Next]** button takes you to the next installation step.

Network parameters

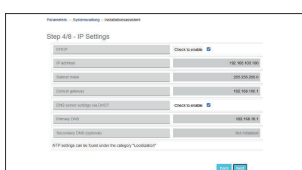
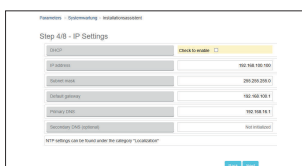

Assignment of IP addresses

By default, IP addresses are assigned using the system's DHCP server. If you wish to use static IP addresses, they must be assigned manually. In this case, the configuration can no longer be distributed using the segment controllers, as these would be included in the configuration, meaning that all inverters in the same segment would end up being configured with the same IP address.

1. Activate DHCP by selecting **'Communication → Ethernet → DHCP'** or, if DHCP is deactivated, enter the IP address.
2. Confirm your selection to proceed.
 - ➔ The **[Next]** button takes you to the next installation step.

Localisation

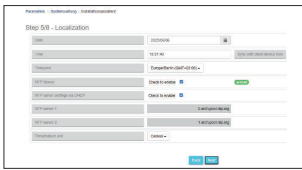

1. Select '**Overview** → **Localisation**' to set the date, time and time zone or to synchronise with the client.

 **Synchronisation requires the activation of an NTP server.**

2. Select the temperature unit via the drop-down menu.
3. Confirm your selection to proceed.
 - ➔ The **[Next]** button takes you to the next installation step.

Modbus



1. Select '**Communication** → **Ethernet** → **Modbus**' to define the Modbus port and activate read/write access.
2. Confirm your selection to proceed.
 - ➔ The **[Next]** button takes you to the next installation step.

Optional parameters

 **Once the device is updated to a newer firmware version, the plant ID enables automatic recognition in the cloud/portal and assignment to the relevant system.**

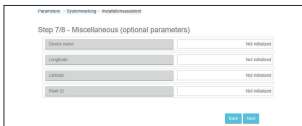

1. Select '**Overview** → **Other**' to enter the device name with which the device can be accessed on the network.

 **The coordinates indicate the device installation location.**

2. Confirm your selection to proceed.
 - ➔ The **[Next]** button takes you to the next installation step.

Finalisation

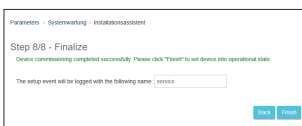

1. Create an installation report (includes a list of all relevant parameters for acceptance purposes).
2. Specify a name for the device installation report.
3. Confirm your selection to proceed.



All settings can also be transferred to another device of the same device series, provided that no individual parameters are required (e.g. a static IP address).

To transfer all settings:

- Export current device settings to the client.

To complete the device configuration successfully:

1. Select **[Finish]**.
 - ➔ Initial commissioning is complete.
2. Define access to the device(s) and activate it using the AC grid user area.

7.6 Commissioning the TESVOLT IoT gateway



There is a TESVOLT IoT gateway in each main cabinet of the TESVOLT FORTON system. All of the following steps must be carried out for each TESVOLT IoT gateway.

The TESVOLT IoT gateway is a development platform for a wide range of software solutions. This enables adaptation to new applications and devices. The following steps are required to carry out commissioning.

Advanced IP scanner



The IP address of the TESVOLT IoT gateway is assigned arbitrarily by the DHCP server.

To set a fixed IP address, proceed as follows:

- Set the IP address using the web interface of the IoT gateway (➔ Chapter 7.6.3 'Installation' on page 85).

To establish a connection to the TESVOLT IoT gateway, the first step is to retrieve the device's IP address:

1. Connect your laptop to the local network LAN 1.
2. Open the *Advanced IP Scanner* software.

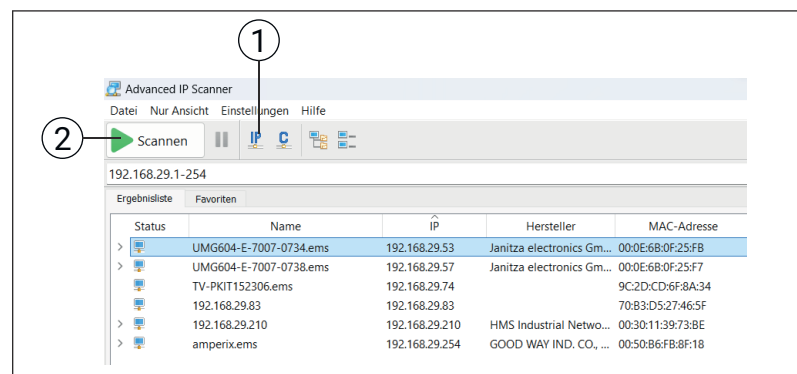

3. Click on the **[IP]** button [1] and select the IP address range.

4. Click on the **[Scan]** button [2].
 - ➔ The software scans the stations on the network and the relevant devices are displayed.
5. Right-click on the **'manufacturer KUNBUS GmbH'** and select **'Copy → IP'**.
 - ➔ The IP address of the TESVOLT IoT gateway is now on the clipboard.

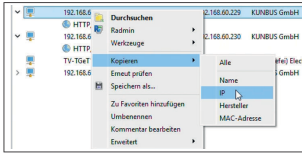

7.6.1 Logging into the TESVOLT IoT gateway

To access the dashboard, proceed as follows:

1. Enter the previously scanned IP address in the browser and confirm.
2. Select **'Continue to (network address)'**.
 - ➔ The dashboard appears.

Log in to the Partner Portal

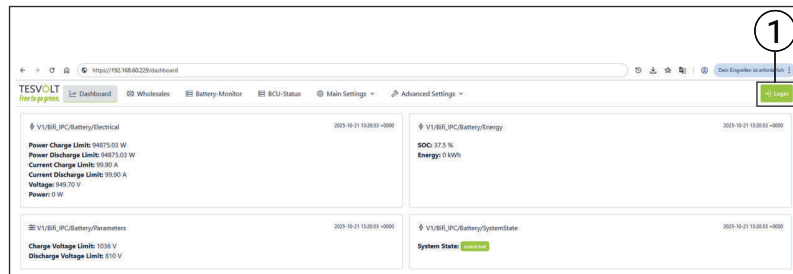

1. Select **[Login]** [1] at the top right of the dashboard.
 - ➔ The TESVOLT Partner Portal window opens.
2. Log into the TESVOLT Partner Portal.
 - ➔ Once you have logged in, the dashboard will appear.

7.6.2 Registering in the TESVOLT Cloud

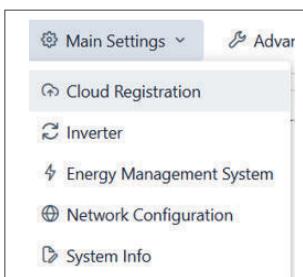

1. Select **'Main Settings → Cloud Registration'** from the menu bar.

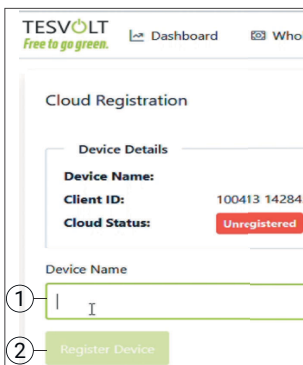

2. Enter the name of the device under **'Device Name'** [1].

Example name:

IoT_name of the specialist partner_project name/end customer_number of the IoT gateway installed in the overall system, i.e. IoT_Sample_FORTON_01

3. To register the device in the TESVOLT Cloud, select, **[Register Device]** [2].
 - ➔ If the device is registered successfully, the message **'Registered'** appears.

7.6.3 Installation

The installation wizard guides you through the installation steps of the TESVOLT IoT gateway.

To start the installation wizard, proceed as follows:

- ▶ Select **[Installation]** from the menu bar.
- ➔ The **'Network Configuration'** area opens.

Configuring the network

- 1.** ▶ Select **'Static IP'** [1].
- 2.** ▶ Enter the network addresses [2].
- 3.** ▶ To save the configuration, select **[Next]** [3].
 - ➔ The dashboard opens and displays the new IP.

Selecting the system type

- 1.** ▶ Select **[Installation]** from the menu bar.
 - ➔ The **'Product Selection'** pane opens.
- 2.** ▶ Select the appropriate **'System Type'**.
- 3.** ▶ To save the configuration, select **[Next]**.
 - ➔ The next installation step appears.

Selecting the battery inverter

- 1.** ▶ Select the appropriate battery inverter under **'Inverter Selection'**.
- 2.** ▶ To save the configuration, select **[Next]**.
 - ➔ The next installation step appears.

Selecting battery communication

- 1.** ▶ Under **'Battery Selection'**, select **'Battery Mode 1 (default)'**.

2. To save the configuration, select **[Next]**.
 - ➔ The next installation step appears.

Saving the installation settings

In the last step, you will see a **'Summary'** of all the settings you have made.

1. Check the summary and change any incorrect settings via the installation wizard.
2. To complete the configuration, select **[Confirm Settings]**.
 - ➔ The TESVOLT IoT gateway is ready for operation.

7.7 Commissioning the TESVOLT Energy Manager

To commission the TESVOLT Energy Manager and activate all devices and energy services, you must complete the steps listed below. All steps are described in detail in the Installation and Operating Manual for the TESVOLT Energy Manager.

Accessing the TESVOLT Energy Manager

To access the TESVOLT Energy Manager:

1. Use the IP scanner to search for the TESVOLT Energy Manager in the network.
2. Enter the IP address of the TESVOLT Energy Manager as a network address in a browser and confirm.
 - ➔ The login interface appears.
3. If you wish, you can change the language (German/English) using the symbol at the top right of the menu bar.

Registering the TESVOLT Energy Manager

For the next step, you will need the PUK of the TESVOLT Energy Manager. This is located on the back of cover 02 in the energy storage system, where it can be found on a black sticker with white lettering.

To complete the TESVOLT Energy Manager registration process:

1. Select the **'Create/Reset credentials'** button.
2. Enter the PUK of the TESVOLT Energy Manager in the first line.
 - ➔ If an initial password is requested instead of the PUK, select the button to the right of the line to switch to PUK entry instead.
3. In the subsequent lines, enter a user name as well as a password that contains at least one uppercase and one lowercase letter as well as a number and a special character.
4. Confirm your entries by clicking the **'Create account'** button.
 - ➔ The login interface appears.

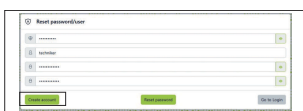
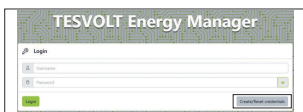

To log into the TESVOLT Energy Manager:

- ▶ Enter the user name and password. Then select **'Login'**.

Configuring the network

After the initial login, the installation wizard guides you through all the necessary commissioning steps.

To configure the network:

- ▶ Configure the network under **'System Settings'**.

Updating the firmware

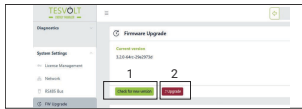

To check and update the firmware version:

1. ▶ Select **'Check for new version'** [1] under **'System Settings → FW Upgrade'**.
 - ➔ The system searches for a new firmware version.
2. ▶ If a new firmware version is available, select **'Upgrade'** [2].
 - ➔ The new firmware version is installed and the device restarts.
3. ▶ Log in with your credentials.
4. ▶ Select **'Finalize'** under **'System Settings → FW Upgrade'**.
 - ➔ The device restarts.
5. ▶ Log in with your credentials.

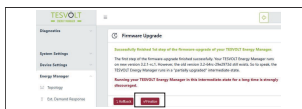

Creating a system in myTESWORLD

To create a new account:

1. ▶ If you do not yet have a MyTESWORLD account, please create one at [↪ https://mytesworld.tesvolt.com/users/sign_up](https://mytesworld.tesvolt.com/users/sign_up).
2. ▶ To check whether all devices are correctly stored in MyTESWORLD, go to the **'Current Status'** area and select **E-Board** (not **'Σ E-Board'**).



3. ▶ In the TESWORLD Energy Manager, go to **'System Settings'** and link it to your myTESWORLD account.

To set up additional user profiles, e.g. for the end customer:

1. ▶ For users who do not yet have an account, please create one for them at [↪ https://mytesworld.tesvolt.com/users/sign_up](https://mytesworld.tesvolt.com/users/sign_up).
2. ▶ Select the relevant permissions under **'Administration → User Permissions'**.

Setting up the TESVOLT FORTON as a device



1. ▶ Select **'Add new inverter'** under **'Device Settings → Inverter'**.
2. ▶ Select **'TESVOLT FORTON'** from the drop-down list.
3. ▶ Enter the IP address and IP port of the TESVOLT IoT gateway [1].

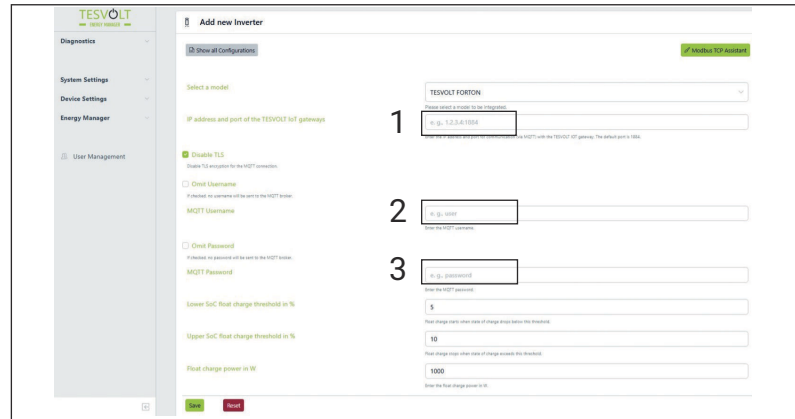

4. Enter *tem* under 'MQTT Username' [2].
 5. Enter *wendeware* under 'MQTT Password' [3].
 6. Adjust the other values and parameters as required.
 7. Select 'Save'.
 - ➔ TESVOLT FORTON will initially be listed as 'Offline'. After a few seconds, the device will be detected and appear under 'Online.'
 8. Set up any other TESVOLT FORTON energy storage systems as required.
- To set up additional devices:
- ▶ Set up all other devices, such as the utility grid transmission power measurement device, under 'Device Settings'.

Assigning device functions

For the TESVOLT Energy Manager to recognise the functions of the individual devices, these functions must be assigned to the corresponding devices.

To assign a function to TESVOLT FORTON:

1. Under 'Device Manager → Topology', select the plus symbol (+) next to the 'Battery' device category.
2. Under 'Device Assignment', assign a separate battery to **each** FORTON system.
3. Mark one power measurement meter as a device for utility grid transmission power measurement.
4. Assign other installed devices to an appropriate device category.

Assigning strategies

Finally, the energy services and strategies must be created and configured in the TESVOLT Energy Manager. Depending on the application, 'Self Consumption' or 'Peak Shaving' are enough to create a simple strategy, while Expert Strategy can be used for complex individual strategies that involve defining specific individual energy services for each device. A strategy always determines what approach all devices should adopt at a given moment. If necessary, you can create several strategies and use the decision tree in the 'Activation' area to define the conditions under which each strategy should be activated.

To create a new strategy:

1. Select 'Strategy +' under 'Energy Manager → Strategies'.
2. Enter a name for the strategy.



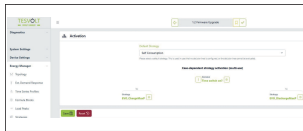

3. ➤ Activate the default strategy in the drop-down menu.



On the same screen, multiple strategies can be linked in a decision tree based on the parameters selected for the decision nodes. You can find more information in the operating manual of the TESPOLT Energy Manager.

To adjust the strategy retroactively:



- Select the name of the strategy under 'Energy Services → Strategy'.



You can set the priority for the installed devices using drag and drop. The TESPOLT Energy Manager will then prioritise the devices from top to bottom according to the defined order, depending on the available power.

7.8 Setting up and configuring the system in the TESPOLT portal

To successfully complete the commissioning process, the system must be created and configured in the TESPOLT portal.

Logging into the portal

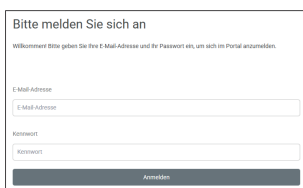

1. ➤ Open the page ➔ <https://portal.tesvolt.com> in your browser.
2. ➤ Log in with your personal credentials.
 - ➔ The TESPOLT portal home screen appears.

Creating a system

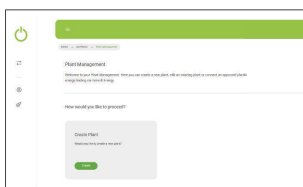

To carry out initial commissioning, a system must be created.

1. ➤ Go to 'Settings → My Plants → Plant Management' and click on 'Create'.
2. ➤ On the 'Create Plant' page, complete all fields marked with * and click on 'Next'.

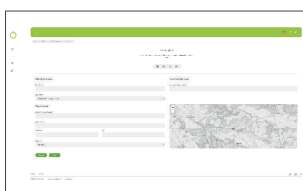

The next page lists all the IoT gateways that have not yet been assigned to a system.

To continue the commissioning process:

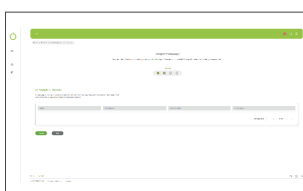

1. ➤ Select at least one IoT gateway by checking the box in the 'Select' column of the table.
2. ➤ Click on 'Next' below the table.
 - ➔ The 'Plant Overview' appears.

Finishing commissioning

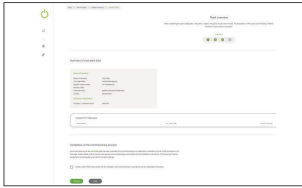

1. → Check all the information entered so far in the *'Plant Overview'*.

2. → Confirm that the commissioning process has been completed correctly by checking the box and click **'Next'**.

➔ Commissioning has been completed successfully.

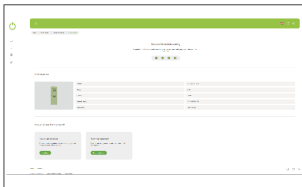

8 Operation

DANGER

Work by unauthorised or unqualified personnel!

Work on the system by unauthorised or unqualified personnel can lead to serious injuries or substantial material damage.

- Work must only be performed by qualified electricians.
- Prior authorisation and appropriate training are required before carrying out any work.
- Comply with applicable safety procedures, standards and legal regulations.

WARNING

Improper use of the measuring instrument or failure to wear personal protective equipment!

Improper use of the measuring instrument or failure to wear personal protective equipment can lead to serious injuries.

- Use the measuring instrument only in accordance with the instructions.
- Use insulated tools and wear suitable personal protective equipment (e.g. insulating gloves).
- Stand on a dry, insulating surface.
- Remove metal objects such as watches, rings or necklaces before starting work.

NOTICE

Material damage due to lightning strikes and voltage surges!

During normal operation, the grid operator may experience a voltage surge or the utility grid may be struck by lightning. These events can cause damage to the energy storage system.

- Take suitable surge protection measures.



Surge protection measures

Surge protection is not included as part of the energy storage system. Whether the protection measures are necessary – as well as their nature and execution – all depend on the local conditions and the applicable electrical regulations.

In the case of outdoor installation, in particular, the operating company is obliged to take suitable protection measures against direct and indirect surges. This may require, for example, the use of Type 1 and/or Type 2 surge protection devices (SPDs) in the building installation or directly at the storage system connection point.

We recommend checking the need for additional surge protection measures with a qualified electrician and implementing them accordingly. The manufacturer assumes no liability for damage caused by insufficient surge protection.



Locking the energy storage system cabinet





During operation:

- Keep the main cabinet and the extension cabinets locked.

8.1 Signal elements on the energy storage system

The display indicates the battery level in four segments. If the battery state of charge is 25%, the first segment lights up continuously. At 50%, the first two segments light up; at 75%, the first three segments light up; and at 100% all four segments light up continuously. During charging, the relevant segment flashes.

Operating status

Display	SOC light strip	System status – illuminated dots	Description
	The light strip indicates the current state of charge (SOC).	LV – blue LED lights up.	The state of charge is displayed, and the LV LED indicates that the control unit is being supplied with 24 V and is ready for operation.
	The light strip indicates the current SOC.	LV and HV – both blue LEDs light up.	The control voltage (24 V) is on (LV) and the controllers are being supplied with power. The DC contactors in the HV unit are closed and the battery voltage is being applied at the output of the HV unit.
	The fully charged segments of the light strip light up continuously. The currently charging segment flashes at 2 Hz.	LV and HV – both blue LEDs light up.	The battery is at least 75% full and is currently being charged further.
	The light strip indicates the current SOC.	LV and HV indicate the hardware status. The system error LED lights up red.	System error
	Complete light strip flashes at 1 Hz.	LV and HV indicate the hardware status. The system error LED and fire alarm LED light up red.	The fire protection system has been triggered.

Display	SOC light strip	System status – illuminated dots	Description
	The light strip does not light up.	-	The energy storage system is out of operation.

8.2 Signal elements on the battery inverter

The three LEDs on the battery inverter indicate the different operating statuses. The LEDs can assume the following statuses.

Statuses:

- LED lights up green: L
- LED flashes green: B
- LED does not light up: X
- LED lights up red: R

Operating status	LED status (on/po/of)			Description
Start	L	X	X	The green "Operation" LED lights up if AC voltage is present, irrespective of the DC voltage. If the LED flashes, internal communication between the components is being established. When it stops flashing, the device is ready for feed-in. If the LED continues to flash, there is a problem with internal communication.
Start of feed-in	L	L	X	The green "Operation" LED lights up. The green "Grid operation" LED lights up after the country-specific waiting period has elapsed. Ready for grid operation. The charging/discharging power is displayed via the web interface. The coupling switch/interface switch audibly switches on.
Feed-in operation at reduced power	L	B	X	The green "Operation" LED lights up. The green "Grid operation" LED flashes because one of the following modes is active: internal power reduction, external power reduction, reactive power request or off-grid operation. Ready for grid operation. The charging/discharging power is displayed via the web interface. The coupling switch/interface switch audibly switches on.
No grid operation	L	X	X	The green "Operation" LED lights up.
Fault	X	X	X	No LEDs light up. Fault affecting the device or AC/DC source

Operating status	LED status (on/po/of)			Description
Fault	X	X	R	<p>The red "Fault" LED lights up.</p> <p>Fault affecting the AC/DC source</p> <p>Conditional special cases:</p> <ul style="list-style-type: none"> ■ No DC voltage present (e.g. DC disconnecting switch opened) ■ DC voltage too low (< start voltage) ■ DC voltage is present (> start voltage), but the communication connection between the front end (operating unit) and back end (control unit) is faulty or interrupted.

Firmware update process

The three LEDs also signal the firmware update process when the USB drive is plugged in. The LEDs can assume further statuses for this purpose.

Statuses:

- LED lights up green: L
- LED rapidly flashes green: GS
- LED slowly flashes green: GL
- LED alternately flashes green: GA
- LED does not light up: X
- LED slowly flashes red: RL

Operating status	LED status (on/po/of)			Description
Process in operation	L	X	X	<p>The green "Operation" LED lights up when the device is ready for use.</p> <p>If an update is being performed using a web server and a USB drive is connected at the same time, the device waits until the USB drive is removed or it performs a reset and restarts.</p>
Process has been started (initialisation)	GA	GL	X	<p>The green "Operation" LED and the green "Feed-in" LED flash rapidly in alternation.</p> <p>The process takes up to five minutes in the case of firmware updates or up to 30 seconds for parameter updates.</p>
Process is being initiated (update)	GS	GS	X	<p>The green "Operation" LED and the green "Feed-in" LED flash rapidly.</p>
The process has been successfully completed.	GL	GL	X	<p>The green "Operation" LED and the green "Feed-in" LED flash slowly at the same time.</p> <p>Check the new SW version via the desktop web interface.</p>

Operating status	LED status (on/po/of)			Description
Fault	X	X	RL	<p>The red "Fault" LED flashes slowly.</p> <p>Process was not completed successfully or a timeout occurred.</p> <p>Removing the USB drive during the initialisation phase triggers a device fault. Inserting the USB drive causes the device to restart.</p>
No fault	X	X	X	No error present.

9 Decommissioning

9.1 Shutting down the energy storage system







CAUTION

Danger due to inability to shut down during active charging/discharging!

Improper shutdown during active charging or discharging can lead to electrical hazards, system damage or personal injury.

- Before shutdown, ensure that the charging and discharging power in the main circuit is below 5 kW.
- Only then perform the shutdown process.
- In case of uncertainty, use measuring instruments to check the power flow.

To shut down the energy storage system, proceed as follows:

- 1.**  Reduce the charging/discharging current to 0 kW using the TESVOLT Energy Manager.
- 2.**  Set the DC circuit breaker of the high-voltage unit on COVER 01 to **[OFF]** (DC circuit).
- 3.**  Switch fuse QF4 on COVER 02 to **[OFF]**.
- 4.**  Open fuse QF3 on COVER 02.
- 5.**  Open fuse QF2 on COVER 03 (heat exchanger).
- 6.**  Open fuse QF1 on COVER 03 (AC auxiliary power supply).
 - ➔ The energy storage system is shut down.

9.2 Activating emergency shutdown



NOTICE

Material damage due to emergency shutdown!

Using the emergency stop function while the system is under load can damage the energy storage system.

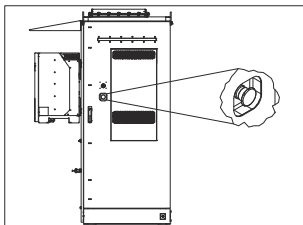
- Only press the emergency stop (E-STOP) button in an emergency.



- 1.**  Press the emergency stop (E-STOP) button.
- 2.**  Open the contactors in the high-voltage unit.
 - ➔ The DC main circuit is disconnected.

10 Inspection and maintenance

WARNING

Danger of death due to electric shock!

At cold temperatures condensation can form on the electronics. This condensation can affect the properties of insulation materials, which may cause an electrical hazard.

Commissioning the system in rain, snow or fog may cause an electrical hazard.

- In the case of low temperatures, snow, rain, thunderstorms or fog, only carry out maintenance or repairs with suitable protective measures in place.

WARNING

Risk of injury when replacing components!

Injuries to the musculoskeletal system can occur when replacing components (battery module, HV unit, etc.).

- Follow workplace safety regulations issued by professional workplace safety organisations and the government.

NOTICE

Material damage due to corrosion!

Excessive corrosion (contact corrosion) can impair the battery inverter's fastening points.

- During regular maintenance/inspection, check the energy storage system for corrosive changes to the battery inverter's fastening points and door hinges.

All protective equipment, work equipment, protection devices, grounding, etc., must be tested in accordance with DIN VDE 0105-100 *Operation of electrical installations* and DGUV 3 and 4.

Maintenance interval

The maintenance interval is **12 months**. If a fault message appears, the fault must be rectified immediately. In special circumstances (e.g. sandstorms), a check must likewise be carried out immediately.



If the storage system is exposed to increased levels of contamination, such as greater amounts of dust and dirt, the maintenance interval must be reduced accordingly. This must be given particular attention and properly assessed during the first year of operation.

10.1 Switching the system on and off for maintenance

10.1.1 Switching on the system

1. → Ensure that the emergency stop (E-stop) button is reset if it was pressed previously.
2. → Set the DC SWITCH on the high-voltage unit to **[ON]**.
3. → Close fuse QF1 (AC auxiliary power supply) on COVER 03.
4. → Close fuse QF2 (heat exchanger switch) on COVER 03.
5. → Close fuse QF3 (uninterruptible power supply, TESVOLT Energy Manager and TESVOLT IoT Gateway) on COVER 02.
6. → Set switch SB1 on COVER 02 to **[ON]**.
 - ➔ The system is switched on.

10.1.2 Switching off the system

1. → Set switch SB1 on COVER 02 to **[OFF]**.
2. → Open fuse QF3 (uninterruptible power supply, TESVOLT Energy Manager and TESVOLT IoT Gateway) on COVER 02.
3. → Open fuse QF2 (heat exchanger switch) on COVER 03.
4. → Open fuse QF1 (AC auxiliary power supply) on COVER 03.
5. → Set the DC SWITCH on the high-voltage unit to **[OFF]**.
 - ➔ The system is switched off.

10.2 Annual maintenance

Area	Requirements and standards	Tests/inspections/tools	System status
Fire extinguishing system	<ul style="list-style-type: none"> ■ Before checking the smoke and gas sensors, remove the wiring of the aerosol fire extinguishing unit. ■ Trigger the smoke detector and gas detector at the same time. ■ Check that the LED indicator and buzzer are working normally. 	Smoke and CO gas sensor testing equipment	OFF

Area	Requirements and standards	Tests/inspections/tools	System status
	<ul style="list-style-type: none"> ■ Before checking the fire alarm, remove the wiring of the aerosol fire extinguishing unit. ■ Trigger the smoke detector and temperature detector at the same time. ■ Check that the LED indicator and buzzer are working normally. 	Smoke and temperature detector testing equipment	
Uninterruptible power supply (UPS)	<ul style="list-style-type: none"> ■ Open the circuit breaker of the high-voltage unit and check that the LED indicator is working properly. ■ Open fuse QF3 and check that the LED indicator is working properly. ■ After the test, close the circuit breaker of the high-voltage unit. 	Visual insp.	OFF
Water immersion sensor	To ensure that the water immersion sensor is working properly, use a test cable to short-circuit its terminals.	Test cable	OFF

10.3 Other maintenance tasks

Area	Requirements and standards	Tests/inspections/tools	System status
Capacity test	Test the capacity based on customer demand.	Testing	ON
Maintenance after an earthquake	Check the energy storage system for structural damage and cable damage.	Visual insp.	ON
	Check that the system is working properly.	Visual insp.	ON
Maintenance after storms and exposure to sand	Check that the energy storage system is undamaged.	Visual insp.	ON

Area	Requirements and standards	Tests/inspections/tools	System status
	Ensure the air filter system is not blocked.	Visual insp.	ON

10.4 Maintenance during normal operation

If the SoC is low (SOC < 30%)

1. Discharge until the shut-off voltage (< 2.8 V) is reached and then pause for 1 h.
2. Charge fully (> 3.55 V) and then pause for 1 h.
3. Discharge to 30% SoC again.

If the SoC is high (SOC > 50%)

1. Charge fully (> 3.55 V) and then pause for 1 h.
2. Discharge until the shut-off voltage (< 2.8 V) is reached and then pause for 1 h.
3. Charge to 30% SoC.

10.5 Maintenance in case of prolonged downtime

1. Carry out and document an inspection every **three months**.
2. Keep the state of charge between 30–50% SoC.
3. To prevent damage to the battery, avoid storage at < 15% SoC.
4. To maintain performance, activate and recharge the battery regularly.

10.6 Replacing the battery module

Battery modules may only be replaced with new modules that are no more than one year old and have a cycle difference of < 300. The voltage difference between the batteries must be < 1 V.

To replace a battery module:

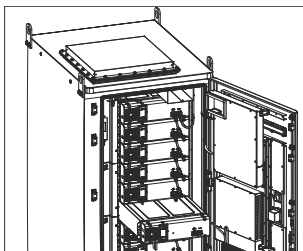

1. Disconnect the power supply and set the DC circuit breaker of the high-voltage unit to **[OFF]**.
2. Remove the module connector.
3. Disconnect the communication cable.
4. Loosen the screws and pull out the battery module.
5. Transport the battery module away.
6. Insert and connect the new battery module.
7. Restore the power supply in accordance with this manual.

10.7 Replacing the high-voltage unit

To replace the high-voltage unit:

1. Disconnect the AC supply and battery inverter connection.

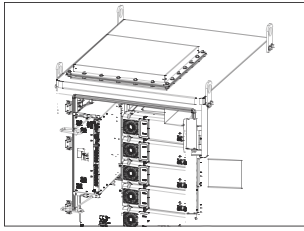

2. ➤ Set the DC circuit breaker of the high-voltage unit to **[OFF]**.
3. ➤ Open the casing.
4. ➤ Remove all cable connections.
5. ➤ Loosen the screws and remove the high-voltage unit.
6. ➤ Install, screw down and connect the new high-voltage unit.
7. ➤ Restart the energy storage system in accordance with this manual.

10.8 Maintaining the heat exchanger

Carrying out a visual inspection at regular intervals

- Check for dust and/or dirt on the surface of the heat exchanger.

Cleaning the heat exchanger

1. ➤ Blow out the dirt with compressed air, ideally against the direction of flow.
2. ➤ In case of heavy soiling, clean using non-corrosive cleaning agents.

Checking for leaks

1. ➤ Check the leak-tightness of the heat exchange elements.
2. ➤ In case of leaks, replace the seals or apply sealant to them.

Removing the fan duct

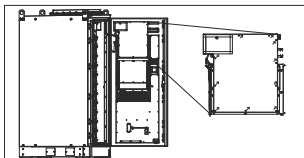

1. ➤ Loosen the M4 screws of the fan duct cover plate using a hex torque wrench.

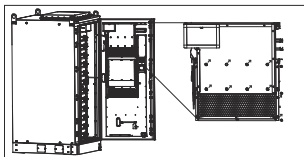

2. ➤ Remove the cover plate.

3. ➤ Loosen the M4 screws of the fan duct assembly using a hex torque wrench.

4. ➤ Loosen the M6 lock nuts using a hex torque wrench.

5. ➤ Remove the fan duct cover plate.

Maintaining the internal recirculation fan

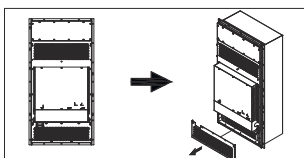

1. ➤ Use a Phillips screwdriver to loosen the screws of the inner cover of the recirculation area and remove the cover.

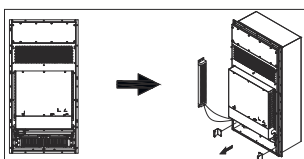

2. ➤ Loosen the heater screws and set the heater to one side to gain access to the heater holder.

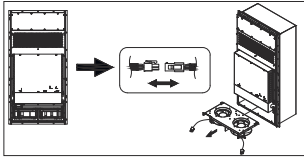

3. ➤ Loosen the screws of the fan assembly, disconnect the fan plug and remove the fan.
4. ➤ Carry out maintenance.

Maintaining the external recirculation fan

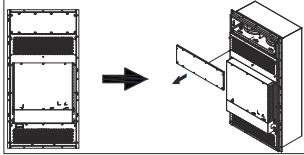

1. ➤ Use a Phillips screwdriver to loosen the screws of the outer cover of the recirculation area and remove the cover.

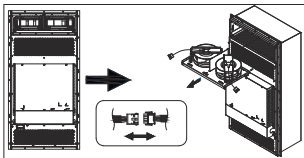

2. ➤ Loosen the screws of the external fan assembly, disconnect the fan plug and remove the fan.
3. ➤ Carry out maintenance.

Maintaining the electrical components

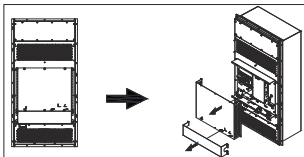

To gain access to the electrical components:

1. ➤ Use a Phillips screwdriver to loosen and remove the screws on the electrical connection box.
2. ➤ Carry out maintenance.

10.9 Replacing the smoke detector

Required tools

- PH2 Phillips screwdriver
- M4 hex socket torque wrench
- Crimping tool
- Insulating tape
- Personal protective equipment

10.9.1 Preparatory work

1. ➤ Ensure that the DC circuit breaker of the high-voltage unit is set to **[OFF]**.
2. ➤ Ensure that the HV and LV LEDs of the LED indicator are switched off.

10.9.2 Removing the smoke detector

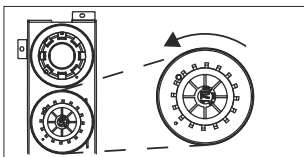

1. ➤ Turn the smoke detector in an anti-clockwise direction and lift it off the cabinet wall.
2. ➤ Before disconnecting the power cable, take a photograph of the smoke detector to help with the subsequent installation process.
3. ➤ Loosen the power cable using a PH2 Phillips screwdriver.
4. ➤ Use the M4 hex socket torque wrench to remove the base of the smoke detector.

5. → Loosen the communication cable on the cable harness and cut through it with a crimping tool.

10.9.3 Installing the smoke detector

1. → Use the quick connectors to connect the new smoke detector communication cable harness to the existing one.
2. → Pull the power cable harness of the smoke detector through the central hole of the new smoke detector base.
3. → Use the M4 hex socket torque wrench to secure the smoke detector base and tighten to a torque of 2 ± 0.2 Nm.
4. → Use the PH2 Phillips screwdriver to secure the power cable harness as per the photograph taken previously and tighten to a torque of 1 ± 0.1 Nm.
5. → Turn the smoke detector in a clockwise direction to attach it to the base.

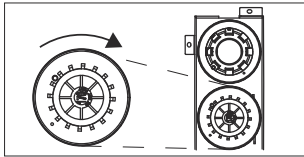

10.10 Replacing the temperature sensor

Required tools

- PH2 Phillips screwdriver
- M4 hex socket torque wrench
- Crimping tool
- Insulating tape
- Personal protective equipment

10.10.1 Preparatory work

1. → Ensure that the DC circuit breaker of the high-voltage unit is set to **[OFF]**.
2. → Ensure that the HV and LV LEDs of the LED indicator are switched off.

10.10.2 Removing the temperature sensor

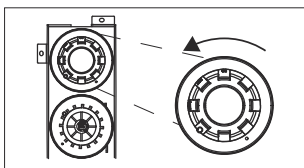

1. → Turn the temperature sensor in an anti-clockwise direction and lift it off the cabinet wall.
2. → Before disconnecting the power cable, take a photograph of the temperature sensor to help with the subsequent installation process.
3. → Loosen the power cable using a PH2 Phillips screwdriver.
4. → Use the M4 hex socket torque wrench to remove the base of the temperature sensor.
5. → Loosen the communication cable on the cable harness and cut through it with a crimping tool.

10.10.3 Installing the temperature sensor

1. → Use the quick connectors to connect the new temperature sensor communication cable harness to the existing one.

2. → Pull the power cable harness of the smoke detector through the central hole of the new smoke detector base.
3. → Use the M4 hex socket torque wrench to secure the temperature sensor base and tighten to a torque of 2 ± 0.2 Nm.
4. → Use the PH2 Phillips screwdriver to secure the power cable harness as per the photograph taken previously and tighten to a torque of 1 ± 0.1 Nm.
5. → Turn the temperature sensor in a clockwise direction to attach it to the base.

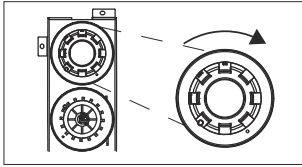

10.11 Replacing the CO detector

Required tools

- PH2 Phillips screwdriver
- M4 hex socket torque wrench
- Crimping tool
- Insulating tape
- Personal protective equipment

10.11.1 Preparatory work

1. → Ensure that the DC circuit breaker of the high-voltage unit is set to **[OFF]**.
2. → Ensure that the HV and LV LEDs of the LED indicator are switched off.

10.11.2 Removing the CO detector

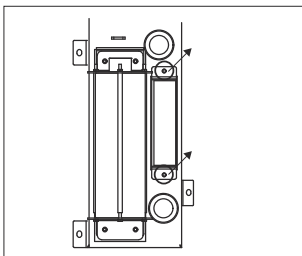

1. → Use an M4 hex socket torque wrench to loosen the fastening screws of the holder.
2. → Disconnect the network cable.
3. → Use the PH2 Phillips screwdriver to loosen the four M3 screws of the holder and remove the CO detector.

10.11.3 Installing the CO detector

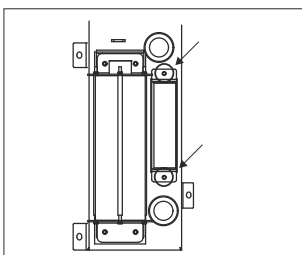

1. → Insert the CO detector into the holder and use the PH2 Phillips screwdriver to tighten the four M3 screws of the holder to a torque of 1 ± 0.1 Nm.
2. → Use an M4 hex socket torque wrench to tighten the two screws on the energy storage system to a torque of 2 ± 0.2 Nm.
3. → Connect the network cable.

10.12 Replacing the lead-acid batteries in the UPS

Required tools

- M4 hex socket torque wrench
- Insulated M6 hex head torque wrench
- Personal protective equipment

10.12.1 Preparatory work

1. Ensure that the DC circuit breaker of the high-voltage unit is set to **[OFF]**.
2. Ensure that the HV and LV LEDs of the LED indicator are switched off.
3. Open the battery disconnecting switch.
4. Use the M4 hex socket torque wrench to loosen the four screws of cover 02 and remove the cover.

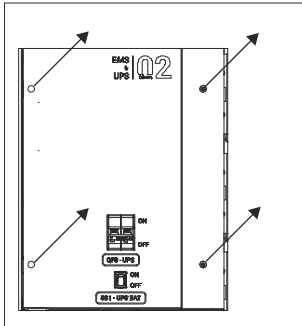

5. Use the insulated M6 hex head torque wrench to loosen the two screws of the UPS and pull out the UPS.

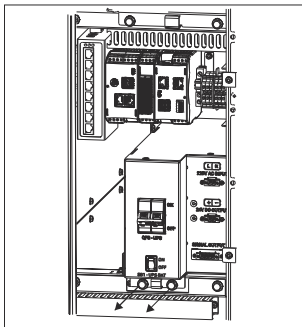

6. Disconnect the cable harness at the UPS.

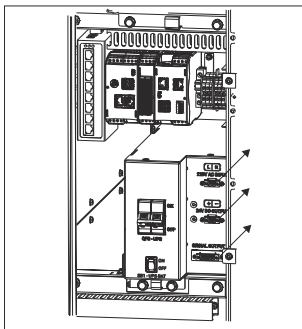

10.12.2 Replacing the lead-acid batteries

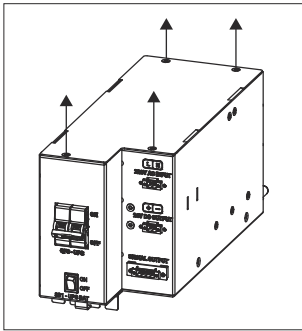

1. Use the M4 hex socket torque wrench to loosen the four screws of the top cover and remove the cover.

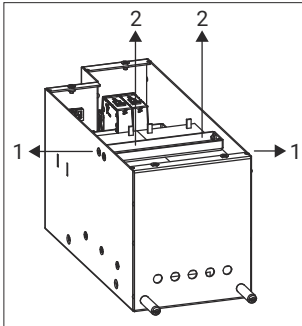

2. Use the M4 hex socket torque wrench to loosen the four screws [1] of the pressure plate.
3. Remove the cable harness of the lead-acid batteries.
4. Remove the pressure plate [2] and replace the batteries.

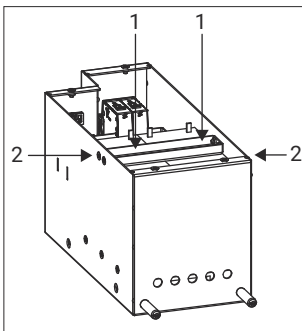

5. Attach the pressure plate and tighten to a torque of 2 ± 0.2 Nm.
6. Connect the cable harness of the lead-acid batteries.

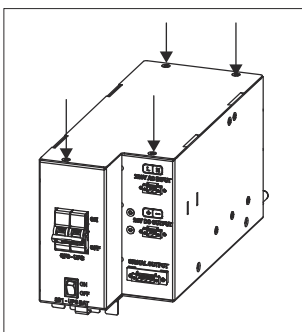

7. Attach the top cover and tighten the four screws to a torque of 2 ± 0.2 Nm.

10.12.3 Final work

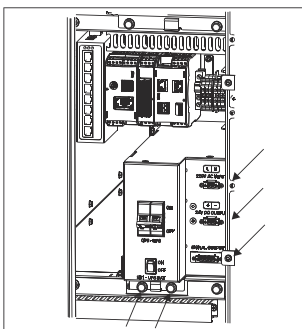

1. Connect the cable harness to the UPS.
2. Insert the UPS and use the insulated M6 hex head torque wrench to tighten the two screws to a torque of 8 ± 1 Nm.

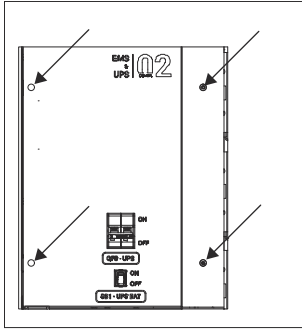

- 3.** Use the M4 hex socket torque wrench to secure cover 02 and tighten to a torque of 2 ± 0.2 Nm.

10.13 Repairing the paintwork

The surface of the energy storage system can get damaged during transport. Although minor damage does not affect the strength of the structure or the safety of the energy storage system, we recommend repairing the paintwork after transport damage.

Preparatory work

- The paintwork must not be repaired in rain, snow, strong winds, sandstorms or other adverse weather conditions, unless suitable outdoor protection measures have been put in place.
- The paint must meet the system equipment performance specifications.
- The relevant instructions (storage, transport, application, scrapping, etc.) must be followed when using the paint.

10.13.1 Requirements

Component	Required coatings	Paint code
Energy storage system cabinet	Slight damage to the coating: Apply one coat.	Top coat: Polyurethane lacquer, RAL 9003
	Severe damage to the coating: Apply two coats.	Primer: Zinc-based epoxy primer Top coat: Polyurethane lacquer, RAL 9003

10.13.2 Carrying out paintwork repairs

Overview

Paintwork damage	Tools and materials	Procedure	Description
Deep scratches (primer damaged, steel base material exposed)	Spray paint or lacquer, zinc-based primer, brush (required if painting a small area), fine sandpaper, anhydrous ethanol, cotton cloth, paint sprayer (required if painting a large area)	Steps 1 – 5 in the next section	<ul style="list-style-type: none"> ■ If there are only a few scratches, stains or spots of rust, we recommend spraying or brushing the paint on by hand. ■ For numerous scratches or large areas of dirt and rust, we recommend using a paint sprayer. ■ The surface must be smooth. The coat of paint must be thin and even. Avoid drips of paint on the coating. ■ The painted area must be left alone for approximately 30 minutes before further work can be carried out.

Repairing paintwork damage



- *The colour of the painted area must match that of the surrounding area. Use a colour meter to measure the colour difference, which should be less than or equal to 3 ($\Delta E \leq 3$). If no colour meter is available, ensure that there is no visible edge between the painted area and the surrounding area. The paint coating must be free of dents, scratches, flaking or cracks.*
- *If you decide to use spray paint, we recommend three sprays before checking the result. If the paint coating does not meet the requirements, repaint as many times as necessary until the required result is achieved.*

- 1.** To remove stains or rust, rub the damaged area with fine sandpaper.
- 2.** To remove dirt and dust, clean the damaged area with a cotton cloth and anhydrous ethanol.



- *If the base material is exposed in the area to be repaired, apply a zinc-based epoxy primer and wait until it has dried. Then apply an acrylic top coat.*
- *Choose a zinc-based epoxy primer or an acrylic top coat matching the colour of the unit's surface coating.*

- 3.** Apply a zinc-based primer to the damaged area with a brush or paint sprayer.
- 4.** Apply the paint evenly to the damaged area using a hand sprayer, brush or paint sprayer according to the degree of damage.
- 5.** Wait 30 minutes and then check that the result meets the requirements.

11 Disposal

GRS batteries – joint take-back system

Batteries can be disposed of free of charge in Germany through the GRS take-back system. To take advantage of this service, please contact TESVOLT Service. Further information is available at: ➔ grs-batterien.de.

Disposal regulations

- Always dispose of batteries in accordance with the current regulations for used batteries.

In case of damage

- Take the battery out of operation.
- Contact the installer or sales partner.

Storage conditions

- Protect the battery from moisture and direct sunlight.



GRS batteries – joint take-back system

- Do not dispose of single-use and rechargeable batteries in household waste! Please note that you are legally obligated to return used single-use and rechargeable batteries.
- Used batteries may contain harmful substances that can damage the environment or harm your health if they are not stored or disposed of properly.
- Batteries also contain important raw materials such as iron, zinc, manganese, copper, cobalt or nickel, and can be recycled.
- Do not dispose of batteries in household waste!

Further information can be found at: ➔ <https://www.tesvolt.com/en/recycling.html>